

INTRODUCTION

- Dimensions - Weights	1
- Identification data and location on vehicle	2
- Performance - Fuel consumption	3
- Capacities	4
- Characteristics of Fiat Lubricant products	5

TECHNICAL DATA

ENGINE

- Characteristics	6
- Typical curves	7
- Cylinder head assembly and valve gear components	8
- Fuel system	9
- Fuel system - Supercharging	10
- Wheels	11
- Electrical equipment	12
- Electronic injection/ignition	13

FREE SERVICE	14
--------------	----

PLANNED MAINTENANCE	15
---------------------	----



For anything not dealt with in this publication refer to the 4WD 1st volume Manual (print n° 504.787/02/03/04/05/06/07/08/09/11/12) and to Manual 505.495/02.

DELTA HF integrale 16v

93 range

Introduction

Dimensions - Weights

00.0

DIMENSIONS

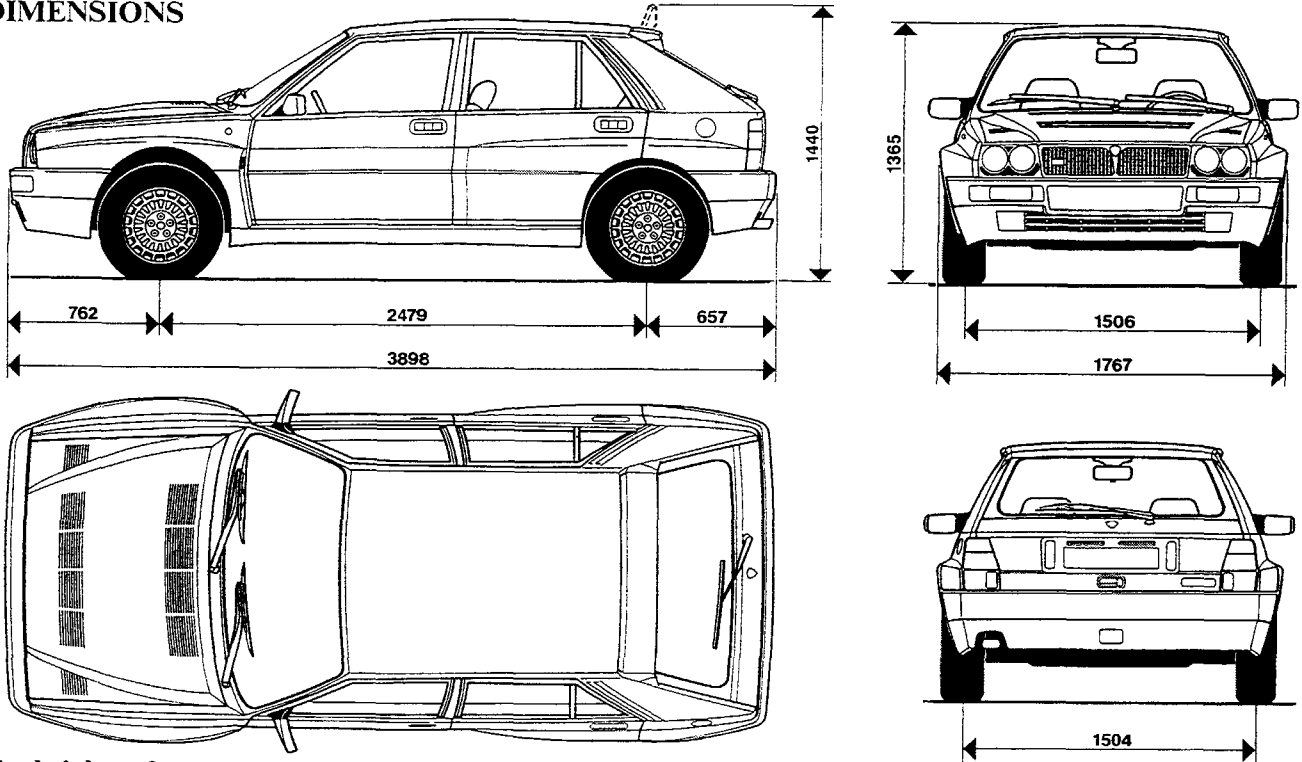

P30001A01





The height refers to an unladen vehicle

Luggage compartment capacity (VDA regulations): 200 dm³.

Load carrying compartment capacity (rear seat folded down)(VDA regulations): 940 dm³.

WEIGHTS

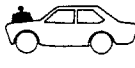
(in kg)

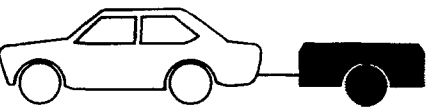
		1340
 + 450 = 		1790
Maximum permissible loads on the axles		1020
		1020
Maximum permissible load on the roof		80
Load on the tow hook (trailer with braking system)		70
	Without braking system	500
	With braking system	800

Loads which should never be exceeded

NOTE FOR ACCESSORIZED VERSIONS: Where there is special equipment (non standard air conditioner, sun roof, device for trailer), the weight of the vehicle when empty increases and therefore the carrying capacity may increase, compared with the maximum permissible loads.

Introduction

Identification data and location on vehicle

DELTA HF integrale 16v
93 range

00.0

IDENTIFICATION DATA

	CHASSIS	ENGINE	VERSION	5 speed gearbox
	ZLA 831 ABO	831 E5.046	831 ABO 29	●

LOCATION OF IDENTIFICATION DATA ON VEHICLE

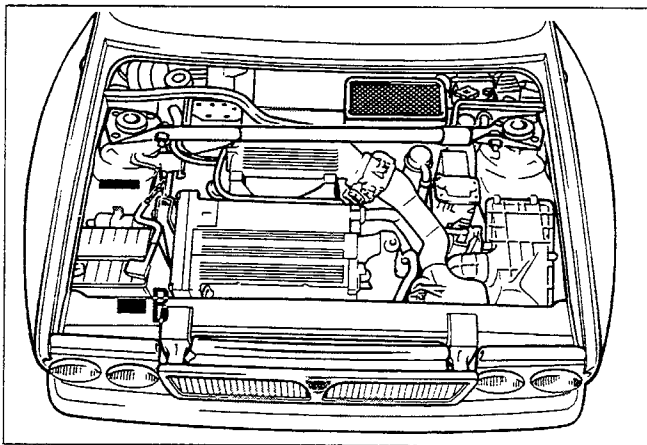

P30002A02 P30002A01

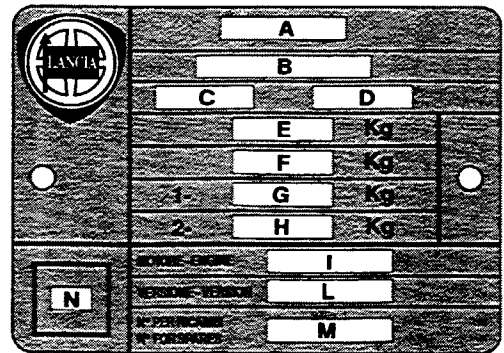

P30002A03

A Chassis number

- Type of vehicle: (ZLA 831 ABO)
- chassis manufacture number.

NOTE The engine type and number are stamped on the engine crankcase behind the engine oil cartridge filter.

B V.I.N. Plate (EEC regulations)

- A. Name of manufacturer.
- B. Type approval number.
- C. Vehicle type identification code.
- D. Chassis manufacture number.
- E. Maximum authorized weight of vehicle fully laden.
- F. Maximum authorized weight of vehicle fully laden plus tow.
- G. Maximum authorized weight on first axle (front).
- H. Maximum authorized weight on second axle (rear).
- I. Bodywork version code.
- L. Engine type.
- M. Spares number.
- N. Correct value of smoke absorption coefficient (for diesel engine).







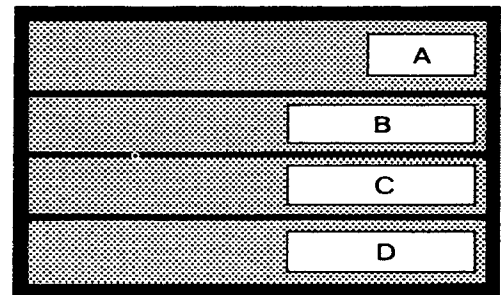







Body paintwork identification plate

It is located inside the engine compartment cover

- A. Paint manufacturer
- B. Description of colour
- C. Colour code
- D. Colour code for retouches or spraying



F30002A01

<p>Speed kph</p> 		62
		100
		142
		188
		220
		62
<p>Maximum climbable gradient</p>  <p>%</p>		58
		40
		25
		17
		12
		68
<p>EEC fuel consumption figures (litres/100 km)</p> 	Urban cycle (A)	13
	Constant speed 90 km/h (B)	8,2
	Constant speed 120 km/h (C)	10,6
	Average consumption (CCMC proposal) $\frac{A+B+C}{3}$	10,6

The fuel consumption figures given in the table have been defined in the course of official tests and in accordance with EEC regulation procedures. In particular, the bench tests measure simulated urban cycle fuel consumption whilst fuel consumption at constant speeds of 90 and 120 km/h are measured both directly on a flat, dry road and in equivalent bench tests. These values can provide useful indications for a comparison between different vehicles. Traffic conditions, driving styles, atmospheric conditions and the general state of the vehicle can, in practice, lead to different fuel consumption figures from those established using the above procedures.



















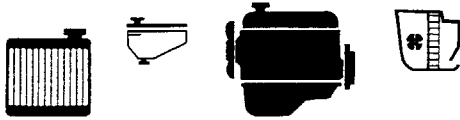





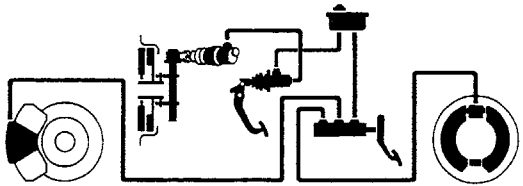

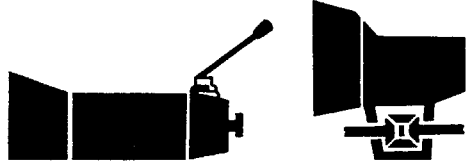



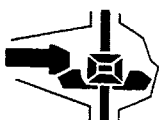
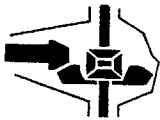

Introduction

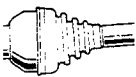
Capacities

DELTA HF integrale 16v

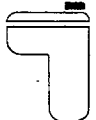
93 range

00.0

Capacities	Unit		Quantity				
			dm ³	(kg)			
 Petrol O.N. 95 unleaded			57	-			
 50% +    H ₂ O ▲ 	Total capacity of cooling system 		6.20	-			
 SELENIA SAE 15W40	Total capacity 		5.90	5.40			
	Partial capacity (periodic replacement)  		5.30	4.80			
 TUTELA TOP 4 (270° C)	Total capacity of hydraulic clutch and braking system 		0.56	-			
 a = TUTELA ZC 80S 			a	3.80	3.40		
 b = TUTELA GI/A 			b	-	-		
 TUTELA W 90/M DA	a 		a	-	-		
	b  Self-locking		b	1.1	1		
 a = TUTELA GI/A	a 		a	0.75	-		
	b = K 854 		b	-	-		
 c = TUTELA MRM2	c 		c	-	0.10		
 H ₂ O + 		3%			2	-	
		~ - 10 °C					50%
		~ - 20 °C					100%

▲ Distilled water

Name of product	Description International designation	Usage
SELENIA SAE 15 W/40	Semi-synthetic multigrade engine oil. Exceeds specifications API SG, CCMC-G4 and UNI 20153	Temperature - 15°C ÷ 40°C
VS MAX SAE 15 W/40	Mineral based multigrade engine oil. Exceeds specifications API SG, CCMC-G4 and UNI 20153	Temperature - 15°C ÷ 40°C
SELENIA Turbo Diesel SAE 15 W/40	Semi-synthetic, multigrade engine oil. Exceeds specifications API CD, CCMC-PD2, UNI 20153	Temperature - 15°C ÷ 40°C
VS MAX Diesel SAE 15 W/40	Mineral based multigrade engine oil. Exceeds specifications API CD, CCMC and UNI 20153	Temperature - 15°C ÷ 40°C
TUTELA ZC 80S	EP SAE 80W oil. Satisfies standards MIL-L-2105 and API GL4	Manual gearboxes and differentials
TUTELA ZC 90	Non EP SAE 80 W/90 oil. for manual gearboxes. containing anti-wear additives.	Gearboxes and non hypoid differentials
TUTELA W 90/M DA	Special sae 80 w/90 ep oil for normal and self-locking differentials. Satisfies standards MIL-L-2105 D and API GL5	Hypoid differentials Self-locking differentials. Steering boxes
TUTELA GI/A	"DEXRON II" type oil for automatic transmissions.	Automatic gearboxes. Power assisted steering
TUTELA CVT Universal	Oil for continuous variation automatic transmissions.	Continuous variation automatic transmissions
TUTELA JOTA 1	Lithium soap based grease. consistency NLGI = 1	Greasing the vehicle except for components particularly exposed to water requiring special greases.
TUTELA MRM2	Water-repellant, lithium soap based grease containing molybdenum disulphide, consistency NLGI = 2	Constant velocity joints
TUTELA MR3	Lithium soap based grease. consistency NLGI = 3	Wheel hub bearings, steering rod, various components
TUTELA PLUS 3 (240 °C)	Synthetic fluid, F.M.V.S.S. n° 116 DOT 3 ISO 4925, CUNA NC 956-01	Hydraulic brakes and hydraulically operated clutches
TUTELA TOP 4 (270 °C)	Synthetic fluid, F.M.V.S.S. n° 116 DOT 4 ISO 4925, CUNA NC 956-01	Hydraulic brakes and hydraulically operated clutches
K 854	Lithium soap based grease. consistency NLGI = 000, containing molybdenum disulphide	Rack and pinion steering boxes
SP 349	Special grease compatible with brake fluid	Load proportioning valve Load proportioning valve rod bush
Arexons DP1	Mixture of alcohol, water and surface agents CUNA NC 956-11	To be used undiluted or diluted in windscreen washer systems
Paraflu"	Mono-ethylene glycol based anti-freeze for cooling system, CUNA NC 596 - 16	Cooling circuits. Percentage to be used 50% up to - 35°C
Diesel Mix Arexons	Additive for diesel fuel with protective action for diesel engines	To be mixed with the diesel fuel (25 cc per 10 litres)

Technical data

DELTA HF integrale 16v

Engine

93 range

00.10



CHARACTERISTICS

	Cycle	OTTO 4 stroke supercharged	
	Timing	with 2 overhead camshafts TOHC	
	Engine balancing	by means of 2 counter balance shafts	
	Fuel system type	Weber-Marelli I.A.W. electronic injection/ignition	
	Number of cylinders	4	
	Cylinder liner (bore)	mm	84
	Stroke	mm	90
	Capacity	cc	1995
	Compression ratio	8	
	Max power	kW (CEE) CV (DIN)	155 (215)
		rpm	5750
	Max torque	daNm (CEE) kgm (DIN)	30.8 (32)
		rpm	2500

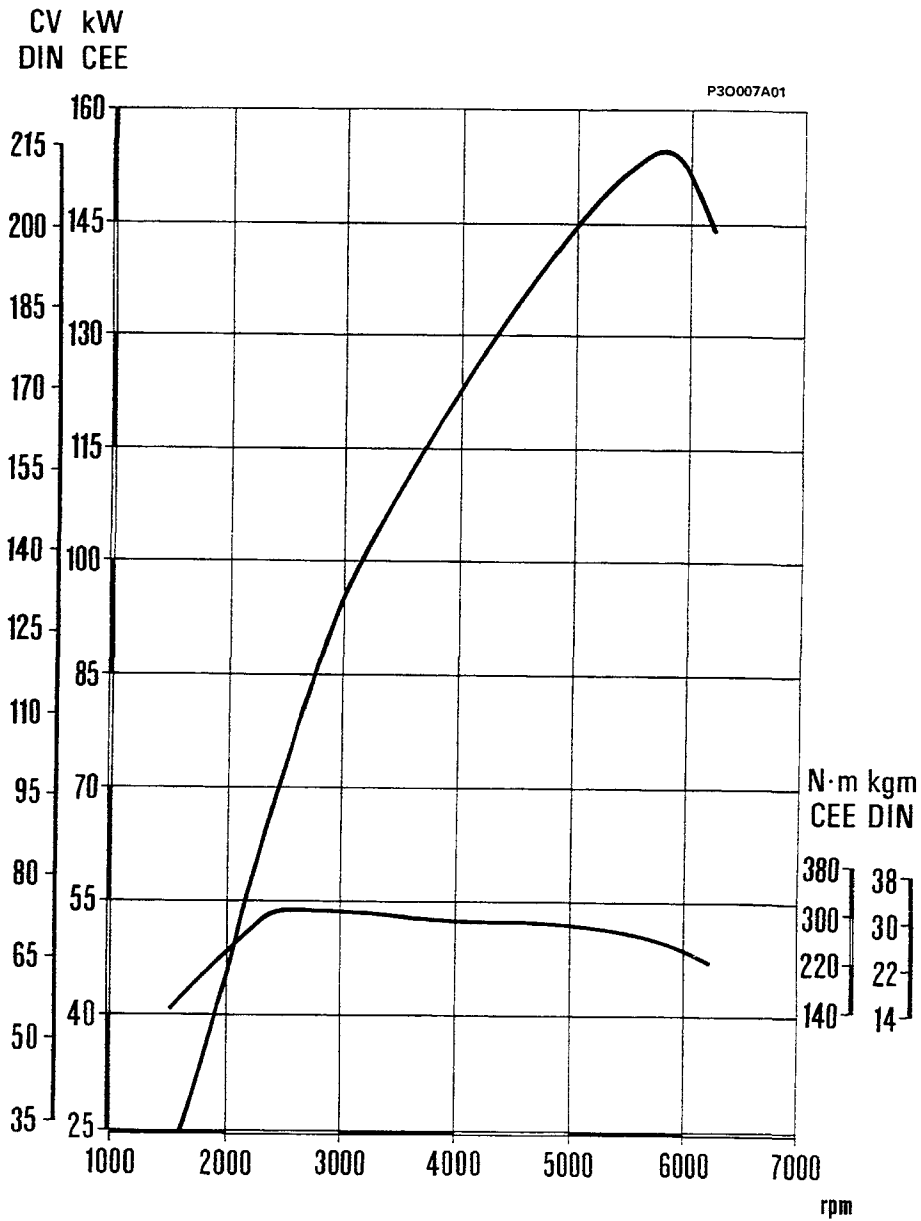

Typical power curves obtained by EEC method

The power curve illustrated can be obtained with the engine overhauled and run in, without a fan, with a silencer and air filter fitted at sea level.

Technical data

DELTA HF integrale 16v

Engine: cylinder head assembly and valve gear components

93 range

00.10



DESCRIPTION

			Values in mm
17 - 20	<p>clearance for timing check</p>		0,80
			0,80
	<p>operational clearance</p>		$0,35 \pm 0,04$
			$0,40 \pm 0,03$

TIMING DIAGRAMS

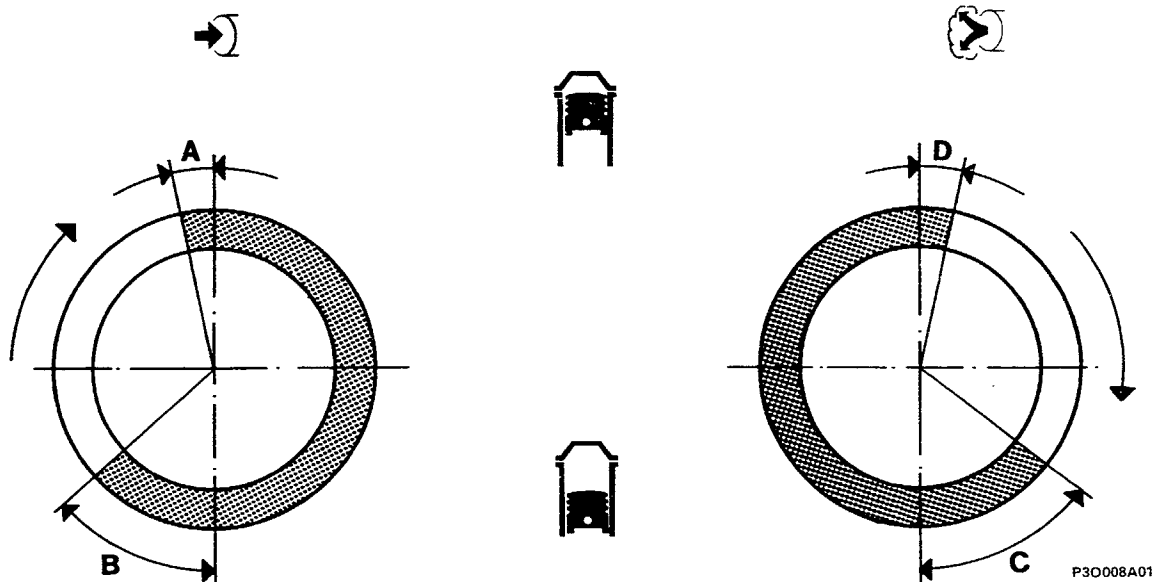

P30008A01



TIMING ANGLES

A	Inlet		opens BTDC	8°
B			closes ABDC	35°
C	Exhaust		opens BBDC	30°
D			closes ATDC	0°

WEBER - MARELLI (IAW) INTEGRATED ELECTRONIC INJECTION/IGNITION SYSTEM COMPONENTS



IAW-4WG injection/ignition system electronic control unit	
Throttle casing	56 CFL 95
Fuel pressure regulator	RPI/3 bar
Injector	IW 058
Automatic idle adjustment solenoid valve	VAE - 06
Electric fuel pump	PI-022
Fuel filter	FI-02/2
Absolute pressure sensor	PRT 06
Throttle valve position sensor (potentiometer)	PF-09
Coolant temperature sensor	WTS - 05
Intake air temperature sender unit	ATS - 04
Lambda sensor (Bosch)	0.258.003.009
Twin relay feed for electric pump and injection/ignition control unit	RSC 240 102
Waste-gate solenoid valve (Pierburg)	7.2105.00

00.10

FUEL SYSTEM

Type	Weber Marelli I.A.W. integrated electronic injection/ignition
Pump	electrical
Capacity	about 120 l/h
Fuel pressure regulator calibration	3 bar

Checking concentration of idle exhaust emissions

	CO (%)	HC (p.p.m.)	CO ₂ (%)
Upstream of the catalytic converter	0.4 ÷ 1	≤600	≥ 12
Downstream of the catalytic converter	≤0,35	≤90	≥ 13



SUPERCHARGING

Turbocharger operated by exhaust gases, cooled by engine coolant and with waste-gate valve and air/air heat exchanger.

Cross section of turbocharger

Turbocharger: type	Garrett T3
Maximum supercharging pressure	1 bar



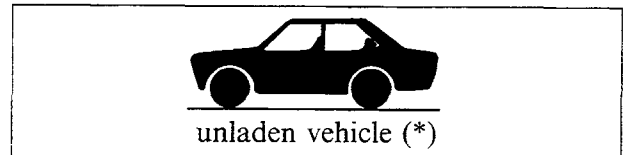
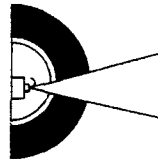

WHEELS

	Tyre	type	205/45 - ZR 16"		
			front	{ average load	2,2 bar
				{ heavy load	2,5 bar
			rear	{ average load	2,2 bar
{ heavy load	2,5 bar				
	Rim	type	light alloy 7½Jx16"H2-37		

NOTE Spare wheel with 3,50 Bx16" H2-37 light alloy rim and T115/70 R16" tyre
Speed limit: 80 km/h. Inflation pressure: 4,2 bar

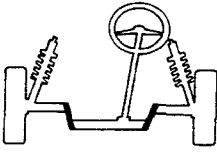

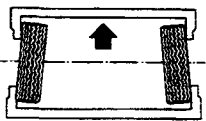
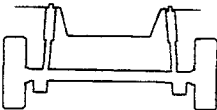
WHEEL GEOMETRY

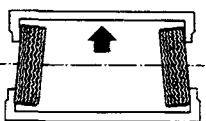
 <p>Front suspension</p>	camber (**)		$- 1' \pm 30'$
	caster (**)		$4^{\circ}10' \pm 30'$
	toe in		$0 \pm 2 \text{ mm } (\bullet)$
 <p>Rear suspension</p>	camber (**)		$- 1^{\circ}30' \pm 30'$
	toe in		$3 \div 5 \text{ mm } (\bullet)$

(*) With tyres inflated to the correct pressure and vehicle in running order (with full fuel tank)

(**) Angles cannot be adjusted (●) Measured between the wheel rims

00.55

SUMMARY OF DATA

STARTER MOTOR	M. Marelli E70R - 1,4 kW - 12 V (with reduction gear)
ALTERNATOR	M. Marelli AA125R - 14 V - 65 A
VOLTAGE REGULATOR	M. Marelli RTT 119 AC
BATTERY	12 V - 55 Ah - 225 A
IGNITION SYSTEM	Weber-Marelli (MPI) integrated electronic injection/ignition
IGNITION COIL	M. Marelli BAE 800 AK
POWER MODULE	M. Marelli AEI 450A
SPARK PLUGS	Bosch WR6 DTC (with three point electrode)

WEBER - MARELLI (IAW) INTEGRATED ELECTRONIC INJECTION/IGNITION CONTROL MODULE

Make and type	Weber-Marelli IAW - 4WG
Firing order	1 - 3 - 4 - 2

IGNITION COIL WITH 2 HIGH TENSION PICK UPS (n° 2)

Make	M. Marelli
Type	BAE 800 AK
Ohmic resistance of primary winding at 20 °C Ω	0,495 ÷ 0,605
Ohmic resistance of secondary winding at 20 °C Ω	6660 ÷ 8140

POWER MODULE

Make and type	M. Marelli AEI 450 A
---------------	----------------------

DETONATION SENSOR

Make	Bosch
Type	0.261.234.095

TDC AND RPM SENSOR

Make and type	M. Marelli SEN 8 D
Sensor winding resistance at 20 °C Ω	578 ÷ 782
Distance (gap) between the sensor and the crankshaft pulley tooth mm	0,4 ÷ 1

IGNITION TIMING SENSOR (HALL effect)

Make and type	M. Marelli SFA 100 A
---------------	----------------------

ADVANCE ON ENGINE

With engine idling (850 ± 50 rpm)	10° ± 2°
-----------------------------------	----------

SPARK PLUGS

Make and type	Bosch WR6 DTC
Thread	M 14 x 1,25
Electrode gap mm	0,8 ÷ 1

00.

FREE SERVICE

Together with the documents which LANCIA supply with every new vehicle, the Owner will receive a free service coupon to be used after 1000 - 1500 km which recommends carryint out the following "Systematic Checks" in accordance with the warranty methods given in the Service Booklet.

Tightening	- inlet and exhaust manifolds
Checks	- CO idle content
Inspections	- ignition advance - correct injector fitting - tyre wear - engine idle speed with possible adjustment - exhaust pipes/silencers with possible adjustments/alignment - door and lid knobs/locks, lubricating if necessary - tightening doors and lids and adjusting if necessary
Check seal of system seals, pipes and unions eliminating leaks and topping up levels, if necessary	- engine lubrication - engine cooling - fuel system - braking system and hydraulically operate clutch - power assisted steering
Check seal of gasket/boots	- gearbox - differential - steering - transmission - shock absorbers
Change	- engine oil - cartridge oil filter - gearbox oil - rear differential oil
Air conditioning system checks	- compressor belt tension - fixing of compressor bolts and pulley - system operation and refrigeration

Lubrication service

The engine oil should be changed every 15,000 Km, or, irrespective of the mileage, every 12 months.

The oil filter should be replaced at the same time as the engine oil is changed.

For the correct and optimum operation of the engine it is advisable to use the type of oil recommended in the table on page 4.



If the vehicle is constantly subject to heavy usage (a great deal of town driving, journies in dusty areas, constant mountain driving, towing a trailer or caravan, harsh climatic conditions, constant motorway driving at high speeds, etc.) then these lubrication services must be carried out at more frequent intervals. In the above mentioned conditions it is also advisable to carry out the Planned maintenance services and the intermediate checks more often.

PLANNED MAINTENANCE OPERATIONS

THOUSANDS OF KM	15	30	45	60	75	90
MONTHS	12	24	36	48	60	72

Check tightening of inlet and exhaust manifolds		☆		☆		☆
Check operation of Lambda sensor			☆			☆
Check idle CO content	☆	☆	☆	☆	☆	☆
Check anti-evaporation system			☆			☆
Check, adjustment tappet clearance		☆		☆		☆
Check condition and wear of tyres	☆	☆	☆	☆	☆	☆
Check operation of front brake pad wear indicator	☆	☆	☆	☆	☆	☆
Check condition and wear of rear brake pads		☆		☆		☆
Visual inspection bodywork exterior and underbody protection	☆	☆	☆	☆	☆	☆
Check condition of pipes (exhaust, supply, fuel system, braking system)	☆	☆	☆	☆	☆	☆
Check condition of rubber elements, boots, hoses, etc.	☆	☆	☆	☆	☆	☆
Check condition and tension of various drive belts and adjust if necessary						☆
Check crankcase ventilation system						☆
Replace fuel filter		☆		☆		☆
Replace air filter cartridge		☆		☆		☆
Changing engine oil and oil filter	☆	☆	☆	☆	☆	☆
Top up fluid levels (engine cooling, braking system, windscreen washer, power assisted steering, hydraulically operated clutch)	☆	☆	☆	☆	☆	☆
Check condition of timing belt				☆		
Check condition of counter balance shaft belt		☆		☆		☆
Check ignition cables	☆	☆	☆	☆	☆	☆
Replace spark plugs	☆	☆	☆	☆	☆	☆
Check ignition/injection system		☆		☆		☆
Change front differential and gearbox oil		☆		☆		☆
Change rear differential oil		☆		☆		☆

00.

Additional operations

In addition to the operations in the "Planned maintenance" programme the following checks are also needed

Every 500 km or before long journies check	- engine oil level - coolant level - brake fluid level - tyre inflation pressure
Every 60,000 km or 2 years change	- engine coolant
Every 105,000 km change	- timing belt - counter balance shaft drive belt
Every 120,000 km change	- gearbox oil
Every 2 years change	- brake fluid

DESCRIPTION	2000 i.e. HF integrale 16v
Starting - I.A.W. electronic injection/ignition - Recharging and warning light - Insufficient engine oil pressure warning light - Injection system failure warning light	10
Parking lights and warning lamp - Dipped headlamps and warning light - Main beam headlamps and warning light - Headlamp flasher - Number plate lights - Direction indicators and warning light - Hazard warning lights and warning light - Reversing lights - Luggage compartment light -	11
Rear fog lamps and warning light - Braking lights - Heated rear windscreen and warning light - Preparation for fog lamps and warning light - Handbrake warning light - Seat belt warning light	1
Electric horns - Car interior ventilation - Front brake pad wear warning light - Insufficient brake fluid level warning light - Insufficient engine oil pressure warning light - Insufficient engine oil warning light - Insufficient coolant level warning light	2
Engine cooling - Fuel level gauge and reserve warning light - Rev counter - Voltmeter - Water temperature gauge and overheating warning light	3
Windscreen wiper - Rearscreen wiper - Electric windscreen washer pump - Electric pump for rearscreen washer	4
Car interior lighting - Oddments pocket light - Cigar lighter - Digital clock - Preparation for radio - Switch light - Instrument panel light and dimmer - Combined instrument - Engine oil pressure gauge - Engine oil temperature gauge	5
Electric front windows - Central locking	6
Electric sun roof	7
Version without control system: Parking lights and warning lamp - Braking lights - Handbrake applied and insufficient brake fluid level warning light - Battery recharging warning light - Front brake pad wear warning light - Insufficient engine oil pressure warning light - Coolant overheating warning light - Rev counter	8
Air conditioning	9
Anti-lock brakes and failure warning light (A.B.S.)	12
Control-System	13

NOTE The numbers in the table correspond to the page number of the electrical equipment in the manual

DELTA HF integrale 16v

93 range

Electrical equipment

Wiring diagrams

55.

Version: 2000 i.e. HF 16v integrale
 Rear fog lamps and warning light - Braking lights - Heated rear windscreen and warning light - Preparation for fog lamps and warning light - Handbrake warning light - Seat belt unfastened warning light - (See key at end of wiring diagrams).

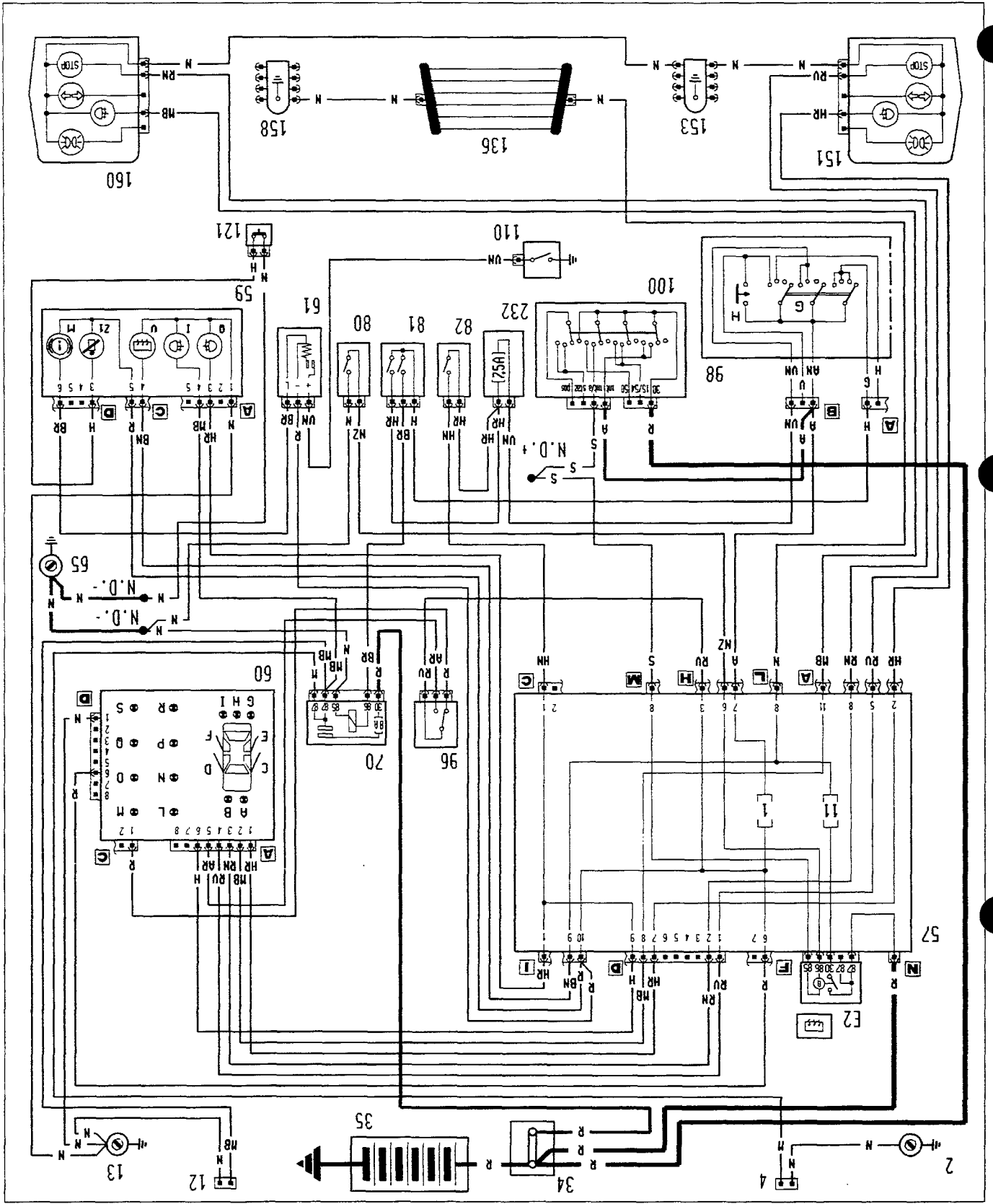

55.

Version: 2000 i.e. HF integrale 16v

Electric horns - Car interior ventilation - Front brake pad wear warning light - Insufficient brake fluid level warning light - Insufficient engine oil pressure warning light - Insufficient engine oil warning light - Insufficient coolant level warning light (See key at end of wiring diagrams)

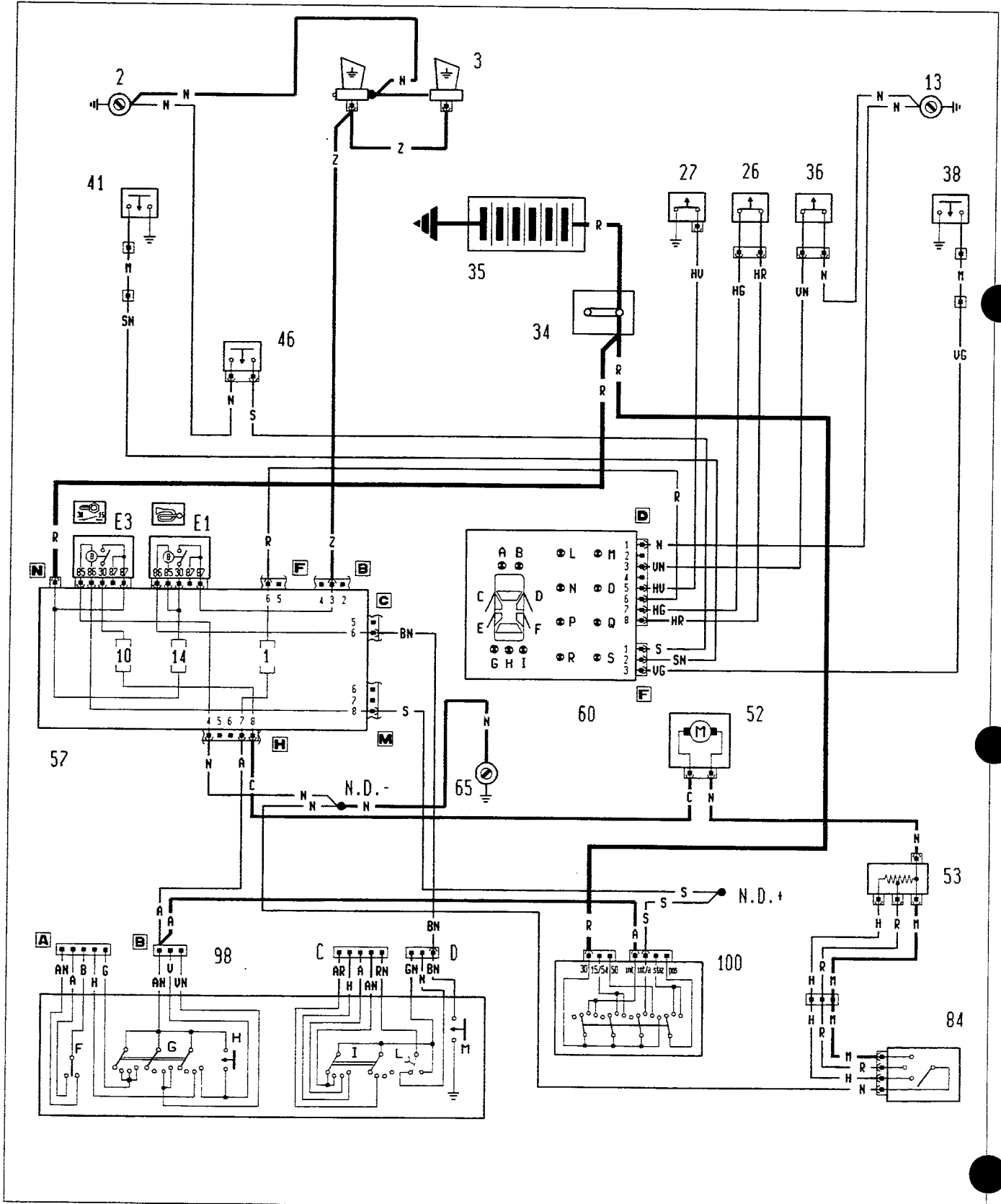

P3002ZL01

Electrical equipment

Wiring diagrams

55.

DELTA HF integrale 16v

93 range

Version: 2000 i.e. HF integrale 16v
 Engine cooling - Fuel level gauge and reserve warning light - Rev counter - Speedometer - Voltmeter - Water temperature gauge and over-heating warning light - (See key at end of wiring diagrams).

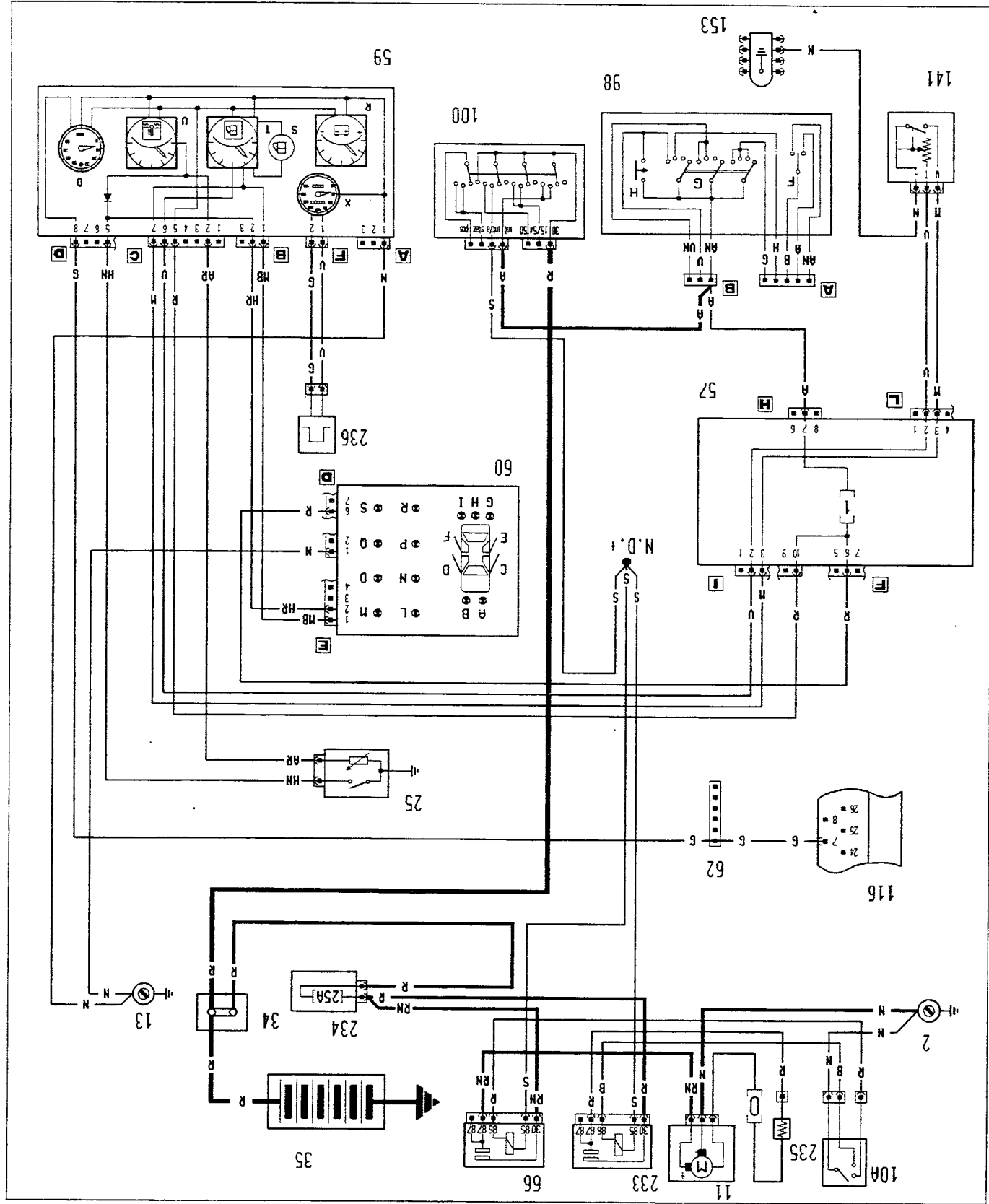

55.

Version: 2000 i.e. HF integrale 16v

Windscreen wiper - Rearscreen wiper - Electric windscreen washer pump - Electric pump for rearscreen washer - (See key at end of wiring diagrams)

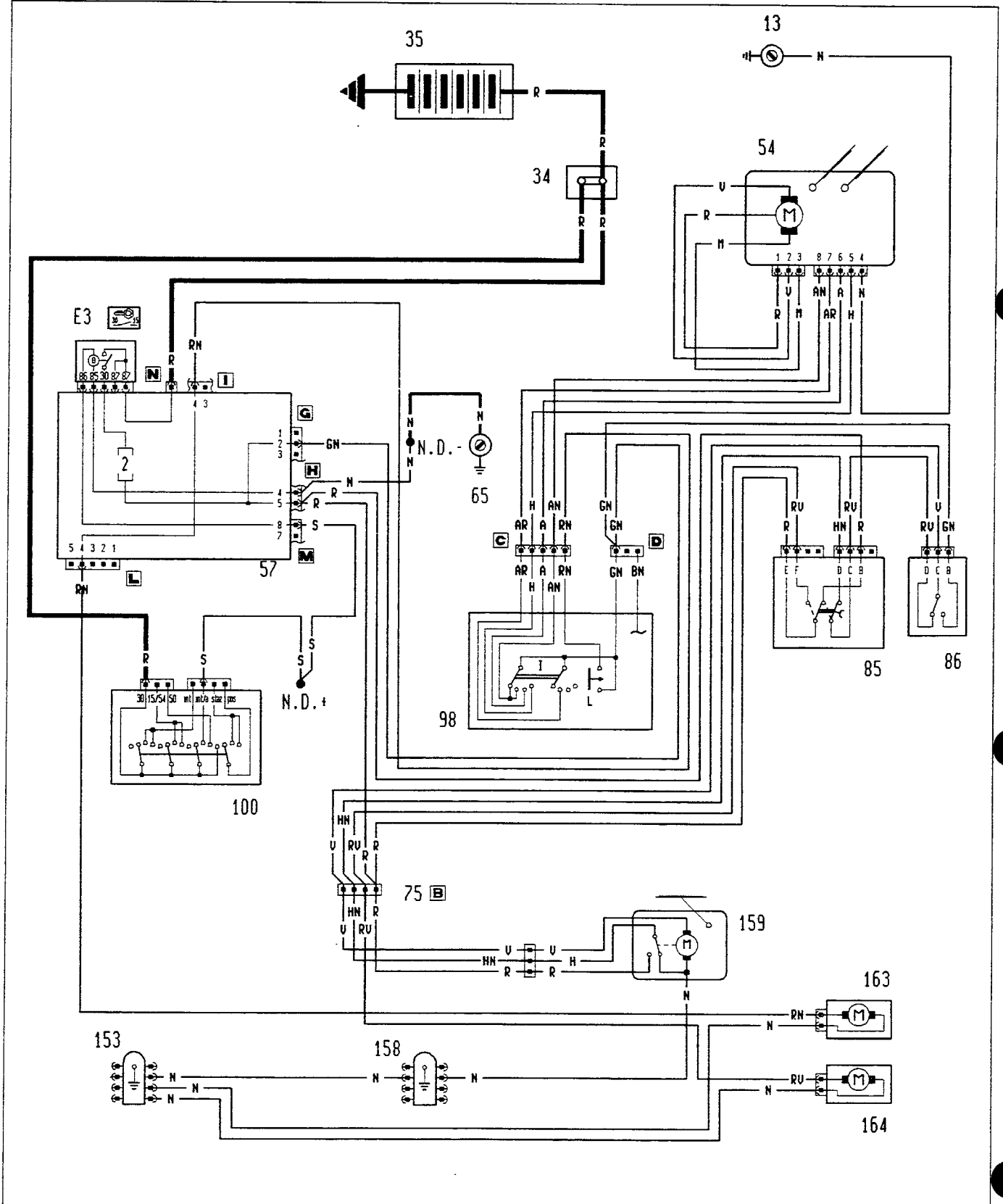

P30042L01

DELTA HF integrale 16v 93 range

Wiring diagrams

55.

Version: 2000 i.e. HF integrale 16v
 Car interior lighting - Glove compartment light - Cigar lighter - Digital clock - Preparation for radio - Switch light - Instrument panel light and dimmer - Combined instrument - Engine oil pressure gauge - Engine oil temperature gauge - (See key at end of wiring diagrams).

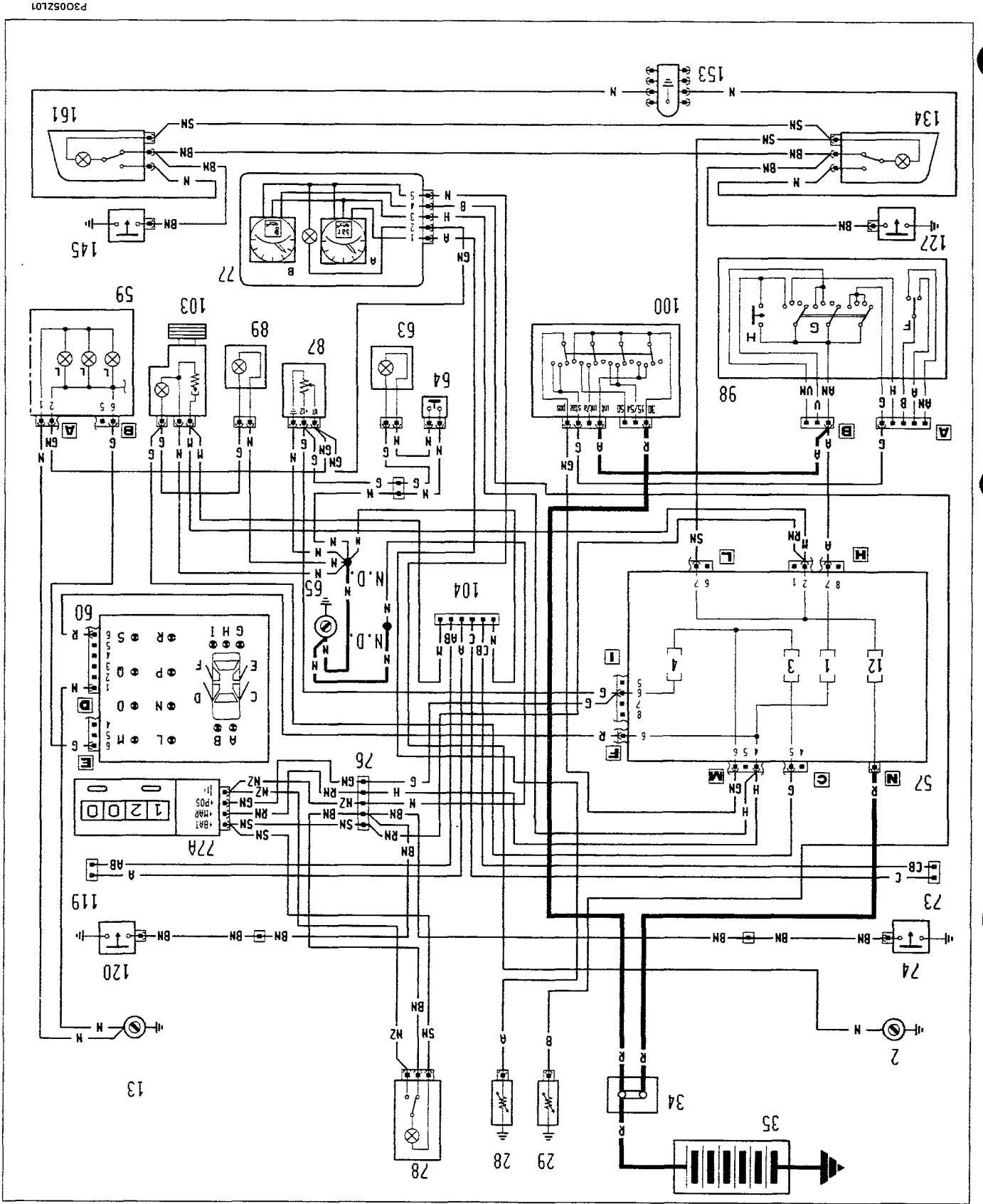

55.

Version: 2000 i.e. HF integrale 16v

Electric front windows - Central locking - (See key at end of wiring diagrams)

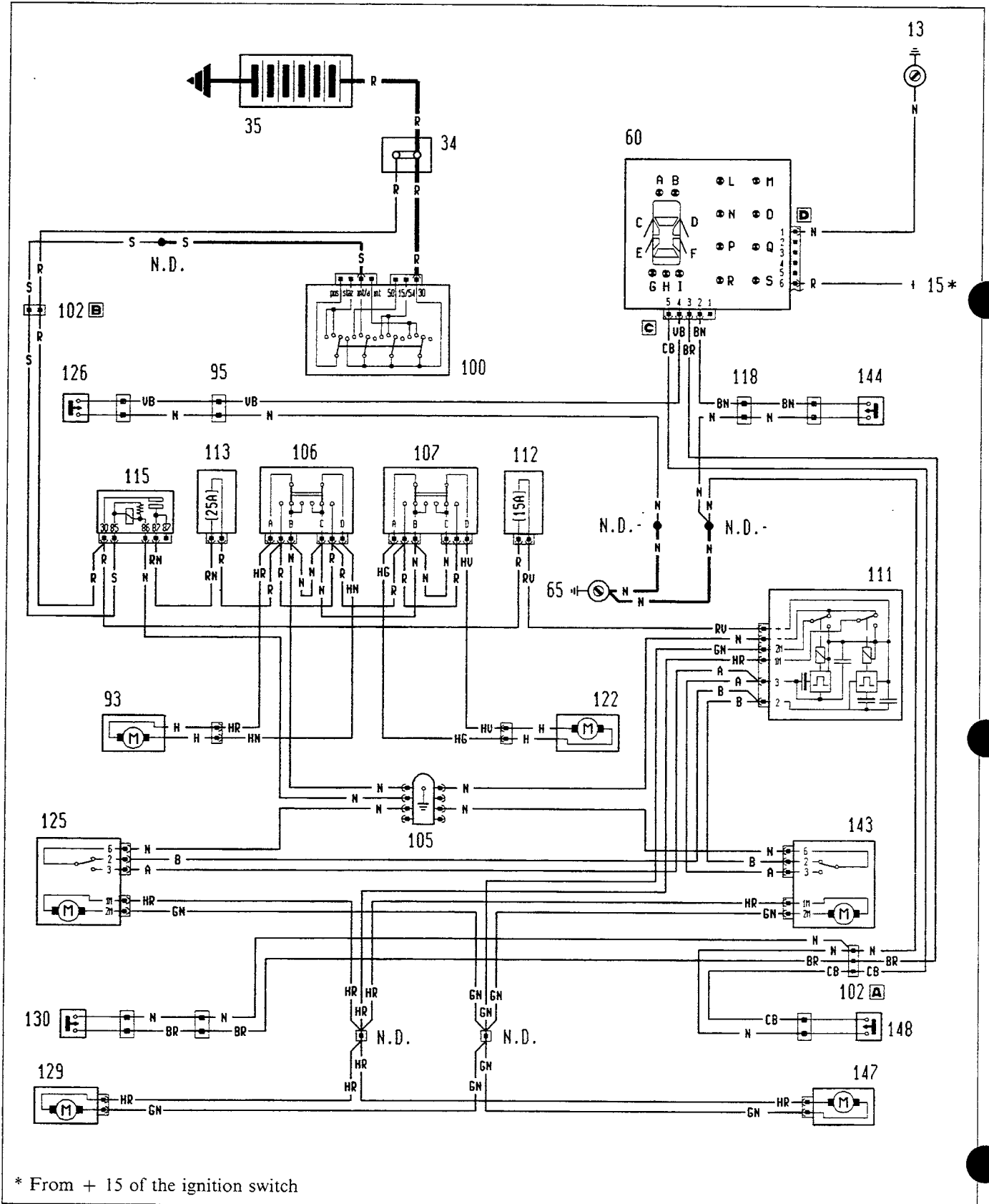

* From + 15 of the ignition switch

Version: 2000 i.e. HF integrale 16v

Electric sun roof - (See key at end of wiring diagrams).

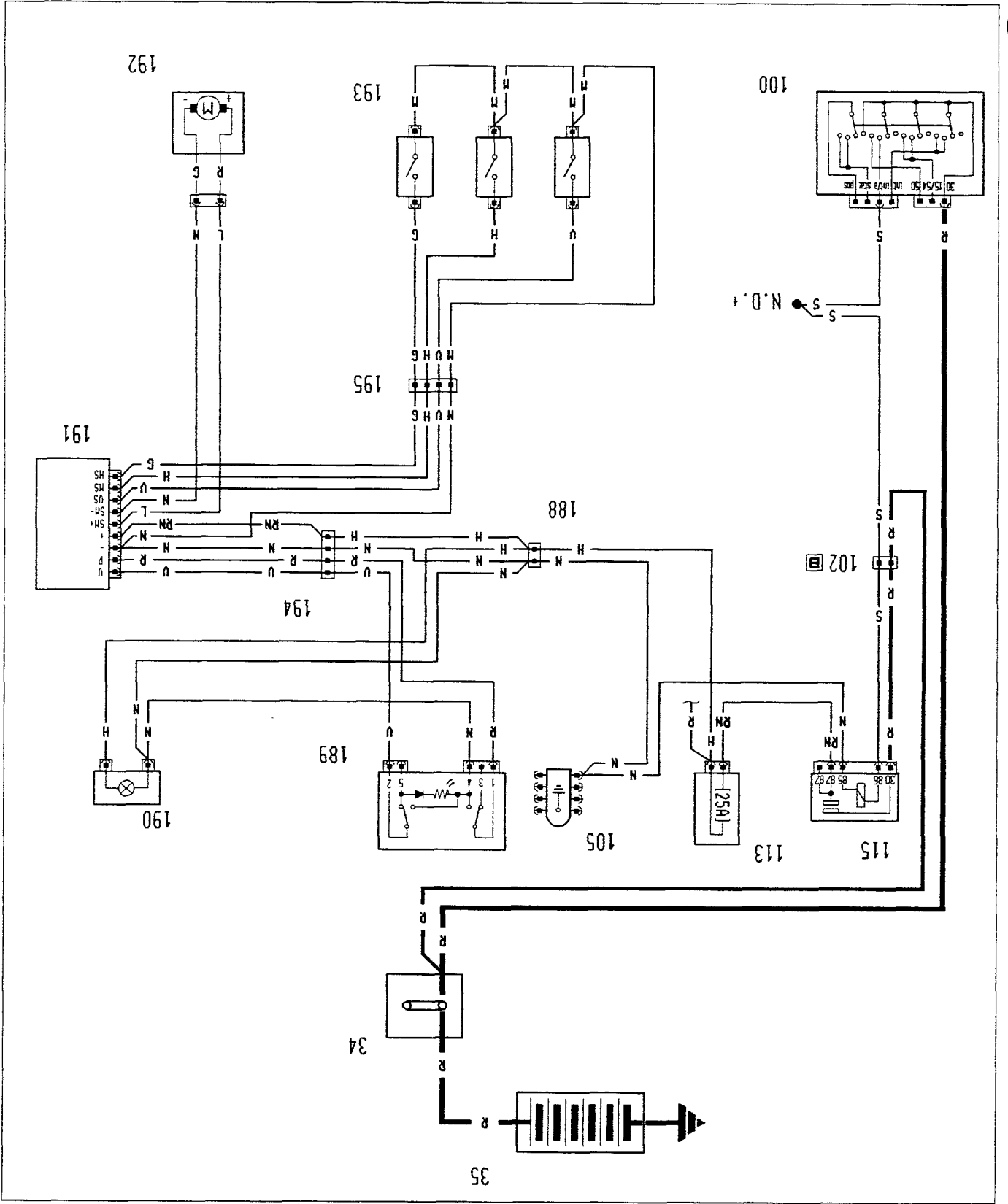

55.

Variant without Control-system: 2000 i.e. HF integrale 16v

Parking lights and warning lamp - Braking lights - Handbrake applied and insufficient brake fluid level warning light - Battery recharging warning light - Front brake pad wear warning light - Insufficient engine oil pressure warning light - Coolant overheating warning light - (See key at end of wiring diagrams)

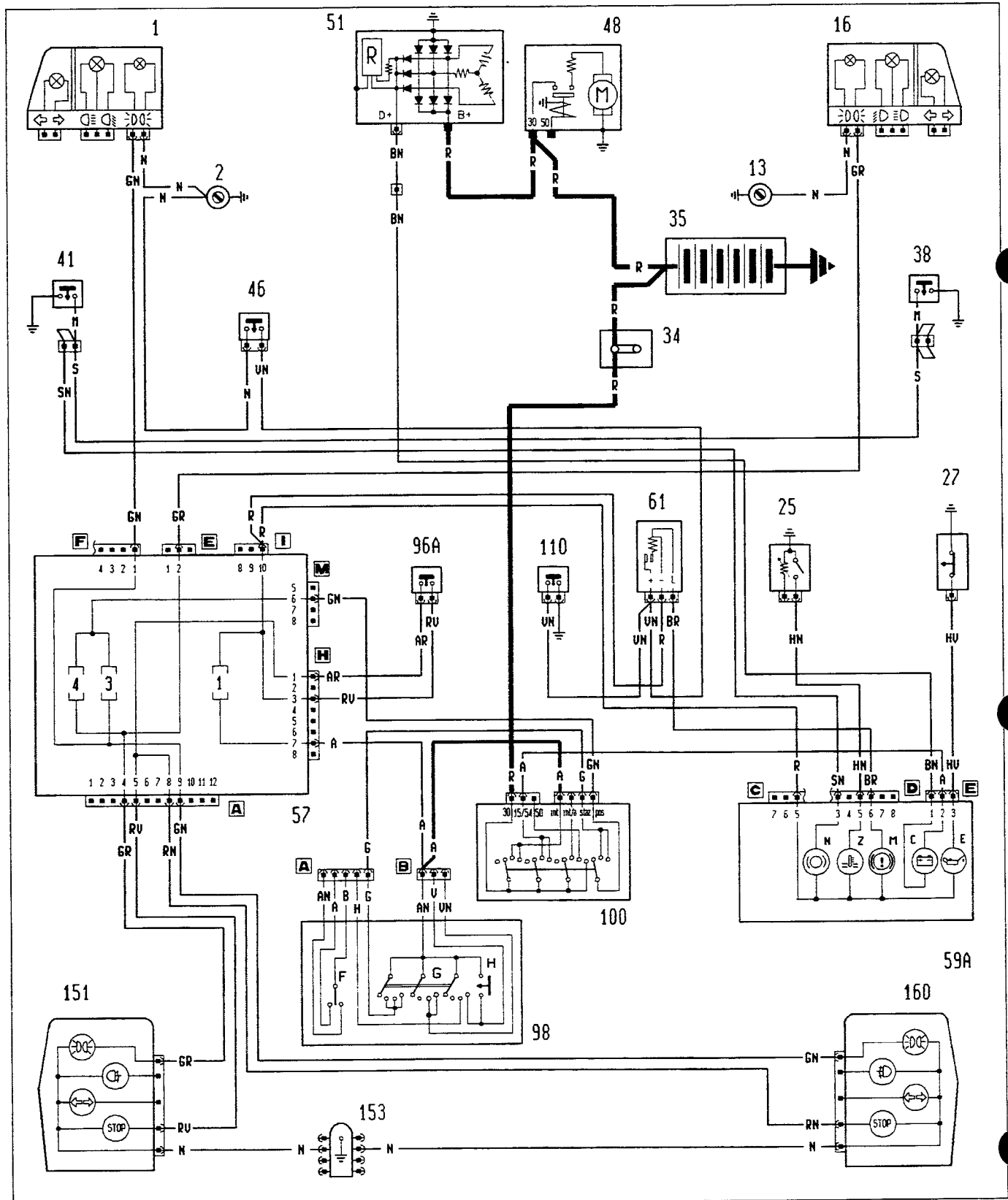

P20082L01

Version: 2000 i.e. HF integrale 16v

Air conditioner (See key at end of wiring diagrams)

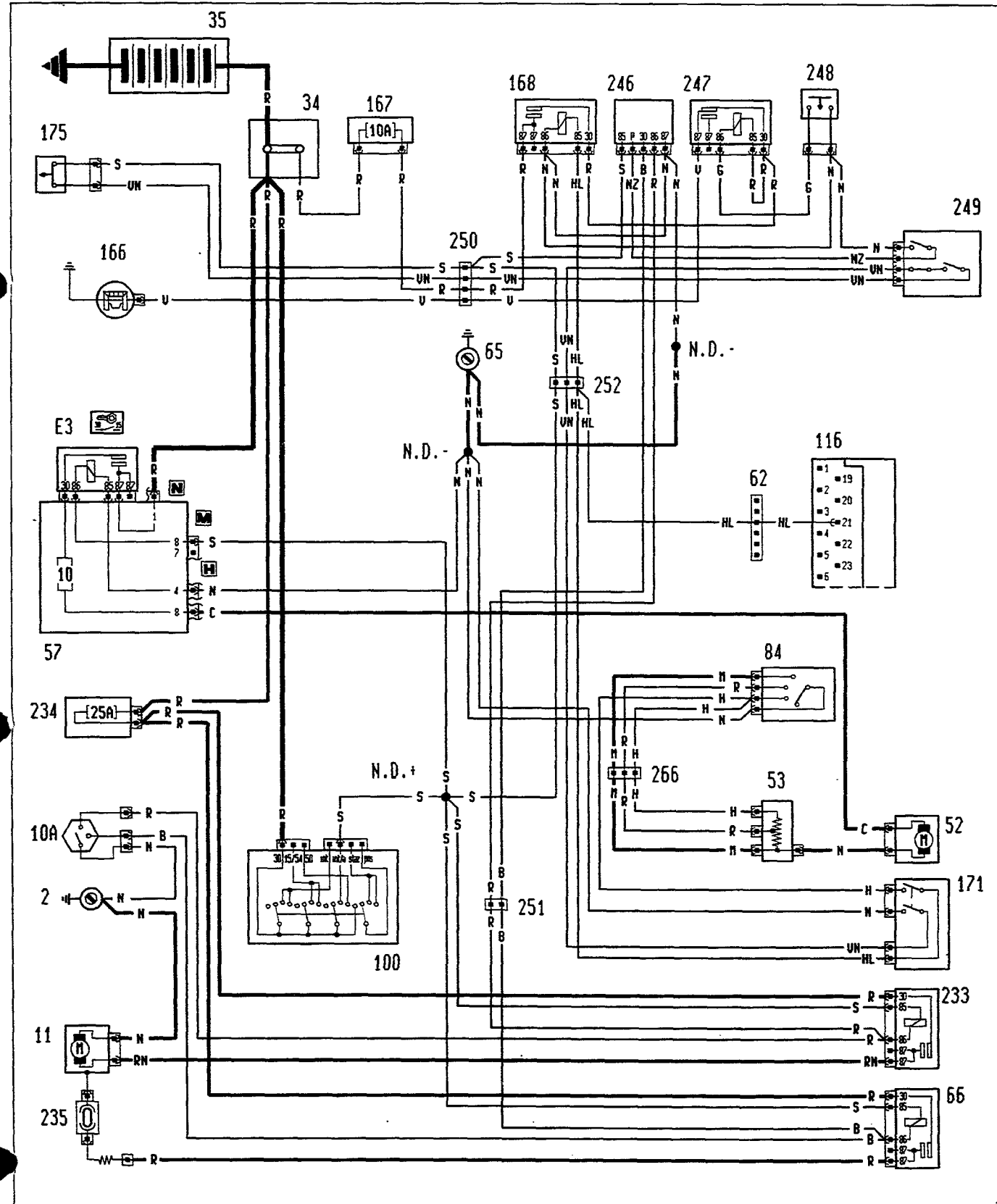

55.

Version: 2000 i.e. HF integrale 16v

Starting - I.A.W. electronic injection/ignition - Recharging and warning light - Insufficient engine oil pressure warning light - Injection system failure warning light - (See key at end of wiring diagrams)

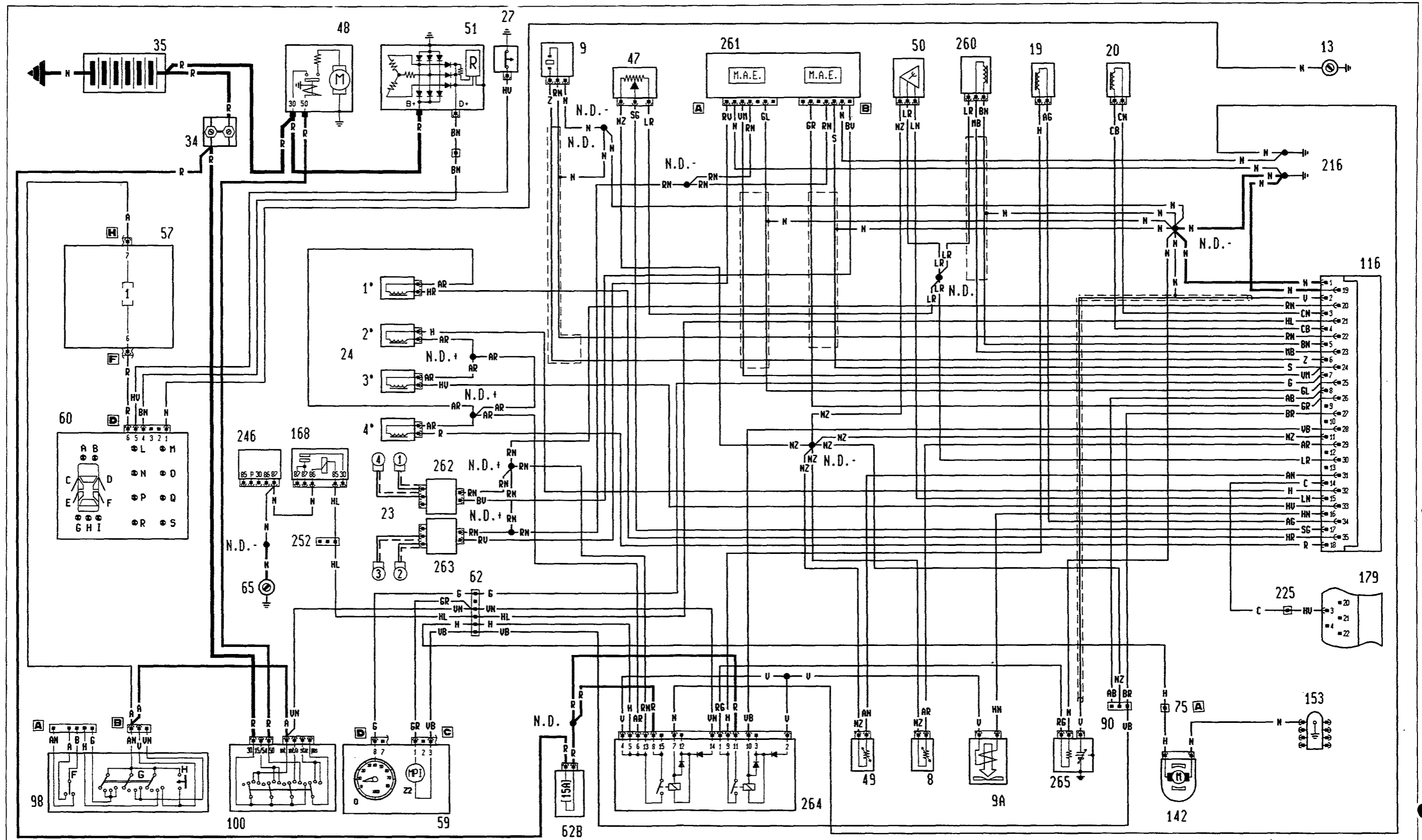

Version: 2000 i.e. HF integrale 16v

Parking lights and warning lamp - Dipped headlamps and warning light - Main beam headlamps and warning light - Headlamp flasher
- Number plate lights - Direction indicators and warning light - Hazard warning lights and warning light - Reversing lights - Luggage compartment light - (See key at end of wiring diagrams).

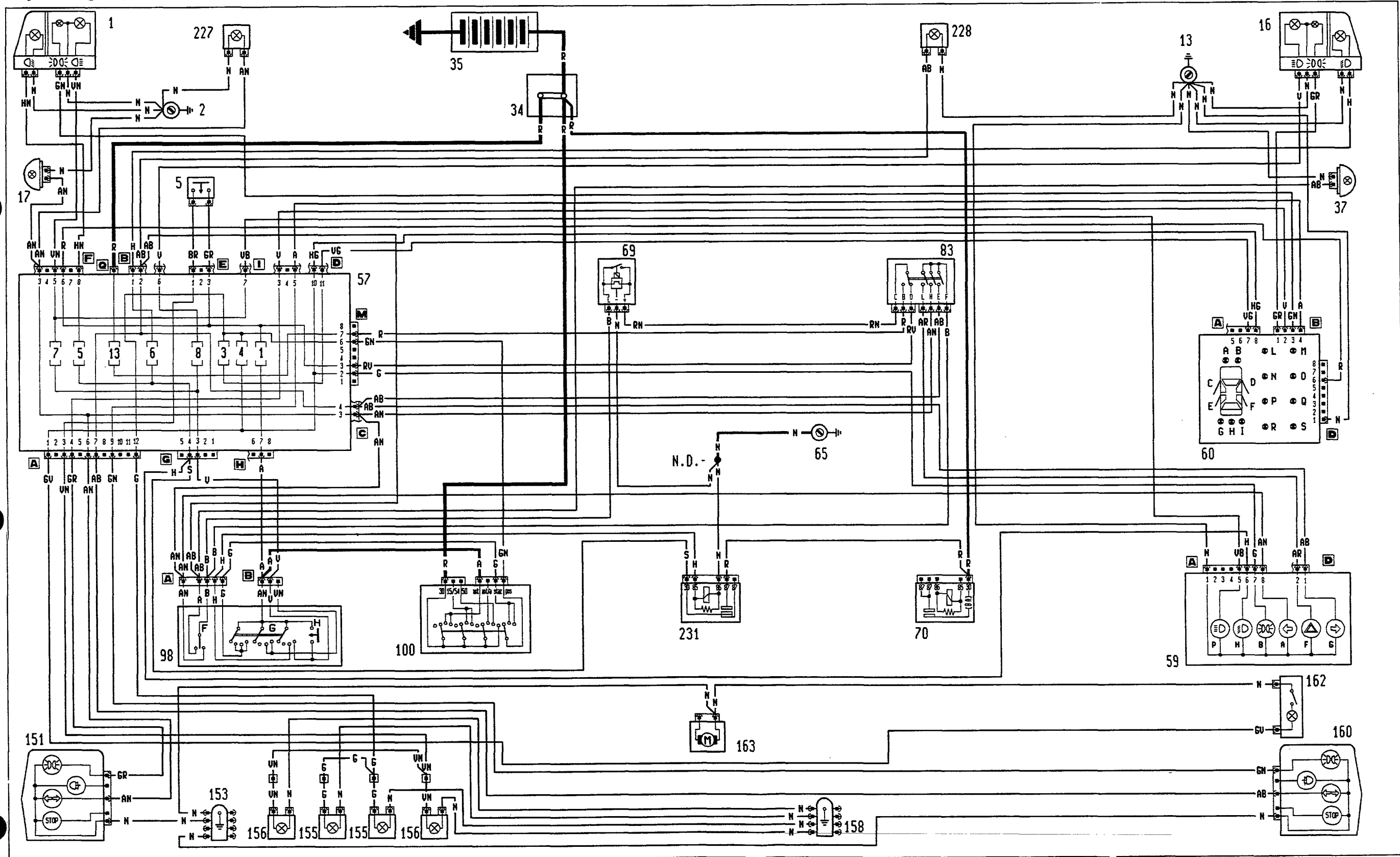

55.

Version: 2000 i.e. HF integrale 16v
Anti-lock brakes and failure warning light (A.B.S.) - (See key at end of wiring diagrams).

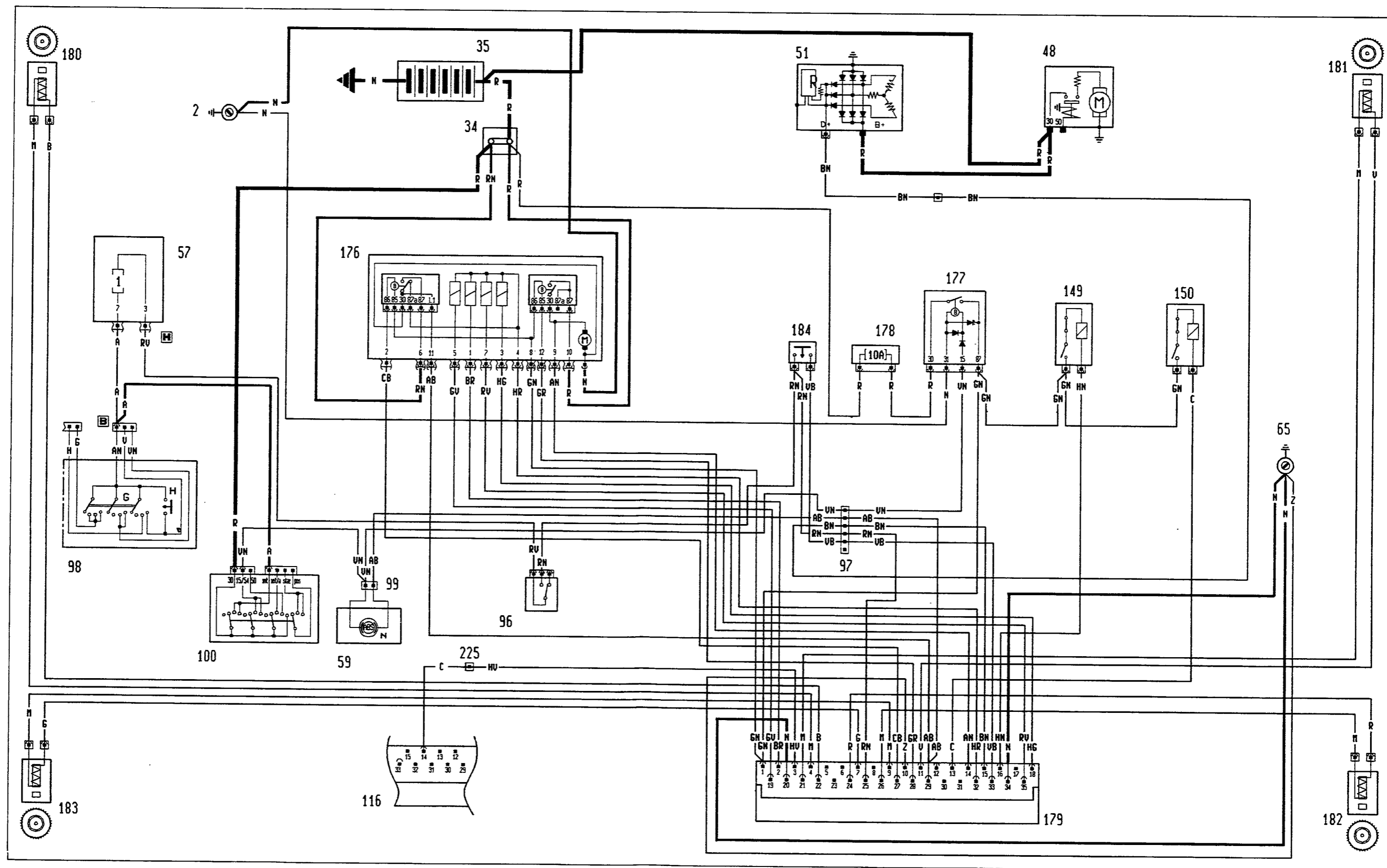

Version: 2000 i.e. HF integrale 16v
Control-System - (See key at end of wiring diagrams).

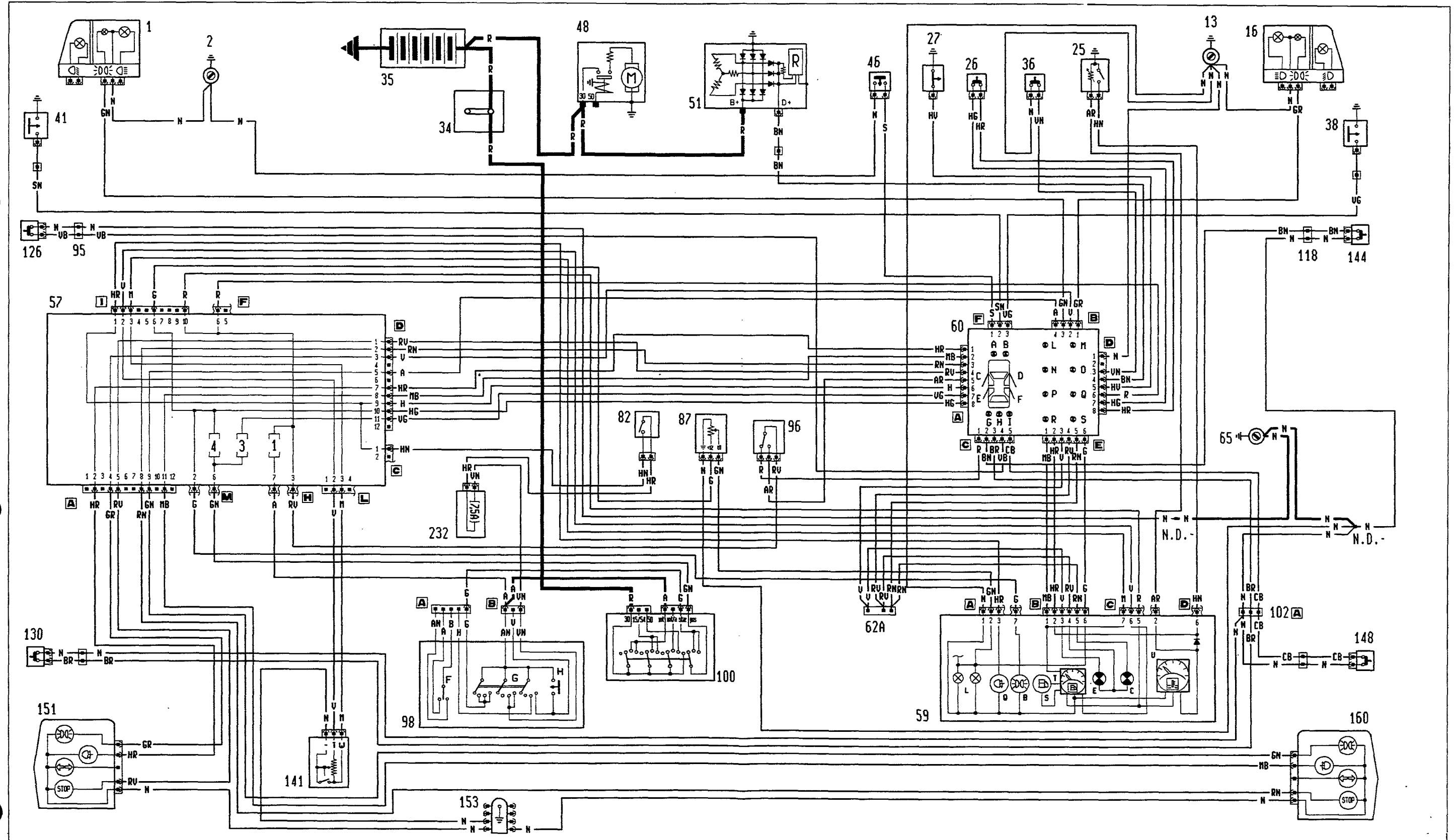

Key for components

- 1 Left front light cluster
- 2 Left front earth cable loom
- 3 Electric horns
- 4 Left fog lamp
- 5 Reversing lights switch
- 8 Engine coolant temperature sensor (I.A.W.)
- 9 Detonation sensor
- 9A Over-Boost solenoid valve
- 10A Thermostatic switch for two stage engine cooling fan
- 11 Radiator cooling fan
- 12 Preparation for right fog lamp
- 13 Right front earth cable loom
- 16 Right front light cluster
- 17 Left side direction indicator
- 19 Automatic idle adjustment solenoid air valve (I.A.W.)
- 23 Spark plugs
- 24 Fuel injectors
- 25 Engine coolant temperature sender unit and switch signalling engine coolant overheating
- 26 Engine oil level sensor
- 27 Insufficient engine oil pressure switch
- 28 Engine oil pressure sender unit
- 29 Engine oil temperature sender unit
- 34 Connector block
- 35 Battery
- 36 Coolant level sensor
- 37 Right side direction indicator
- 38 Right front brake pad wear sensor
- 41 Left front brake pad wear sensor
- 46 Brake fluid level sensor
- 47 Butterfly valve position sensor (I.A.W.)
- 48 Starter motor
- 49 Air temperature sensor (I.A.W.)
- 50 Absolute pressure sensor
- 51 Alternator
- 52 Heater fan
- 53 Electric fan speed resistor
- 54 Windscreen wiper motor
- 57 Fuse and relay junction unit:
 - E1 Electric horn relay
 - E2 Heated rear windscreen relay
 - E3 Ignition discharge relay
- 59 Instrument panel:
 - A Left side direction indicators warning light
 - B Side lights warning light

- C (Red) general warning light for Control-System
- E Starting go-ahead signal (green)
- F Hazard warning lights warning light
- G Right side direction indicators warning light
- H Dipped headlamps warning light
- I Fog lights warning light
- L Instrument panel light bulbs
- M Handbrake warning light
- N A.B.S. failure warning light
- O Rev counter
- P Main beam headlamps warning light
- Q Rear fog lamps warning light
- R Voltmeter
- S Fuel reserve warning light
- T Fuel level gauge
- U Coolant temperature gauge
- V Heated rear windscreen warning light
- X Electronic tachometer
- Z1 Seat belts not fastened warning light
- Z2 Injection system failure warning light
- 59A Instrument panel (version without Control-System)
 - C Battery recharging warning light
 - E Insufficient engine oil pressure warning light
 - M Handbrake applied and insufficient brake fluid level warning light
 - N Front brake pad wear warning light
 - O Rev counter
 - Z Coolant overheating warning light
- 60 Control-System :
 - A Left front side light failure warning light
 - B Right front side light failure warning light
 - C Left front door ajar warning light
 - D Right front door ajar warning light
 - E Left rear door ajar warning light
 - F Right rear door ajar warning light
 - G Warning light signalling failure with side lights, left rear brake light
 - H Rear fog lamps warning light
 - I Warning light signalling failure with side lights, right rear brake light
 - L Insufficient brake fluid level warning light

- M Front brake pad wear warning light
- N Insufficient engine oil pressure warning light
- O Battery recharging warning light
- P Insufficient engine oil level warning light
- Q Insufficient coolant level warning light
- R Automatic transmission fluid overheating warning light
- S Engine coolant overheating warning light
- 61 Intermittent device for handbrake warning light
- 62 Connection for electronic injection cables
- 62A Control-System diagnostic socket
- 62B 15A protective fuse for injectors and electric fuel pump
- 63 Glove compartment light
- 64 Glove compartment light push button
- 65 Earth cable loom under dashboard
- 66 Engine cooling fan 1st speed relay
- 69 Intermittent device for direction indicators and hazard warning lights
- 70 Fog lights relay
- 73 Left front speaker wiring
- 74 Front courtesy light push button on left front pillar
- 75 Connector for left longitudinal cables
- 76 Connector for courtesy light cables
- 77 Combined instrument
 - A Oil pressure gauge
 - B Oil temperature gauge
- 77A Digital clock
- 78 Front courtesy light
- 80 Heated rear windscreen switch
- 81 Fog lights switch
- 82 Rear fog lamps switch
- 83 Hazard warning lights switch
- 84 Heater fan switch
- 85 Rearscreen wash/wipe switch
- 86 Rearscreen wiper switch
- 87 Instrument panel and Control system light dimmer
- 89 Switch light
- 90 Diagnostic socket for injection system
- 93 Left front electric window motor
- 95 Connecting for cables signalling left front door ajar
- 96 Brake lights switch
- 96A Brake lights switch

- 97 Connection for anti-lock braking system cables
- 98 Steering column switch unit
 - A Connector
 - B Connector
 - C Connector
 - D Connector
 - E Connector
 - F Direction indicators operation
 - G Operation of side lights, dipped headlamps, main beam headlamps
 - H Operation of headlamp flashers
 - I Operation of windscreen wiper
 - L Operation of windscreen washer
 - M Operation of electric horns
- 99 Preparation for anti-lock braking system failure warning light
- 100 Ignition switch
- 102 Connection for cables for electric windows/-central locking/signalling doors ajar
- 103 Cigar lighter
- 104 Preparation for radio
- 105 Earth point on central tray
- 106 Left front electric window switch
- 107 Right front electric window switch
- 110 Push button for handbrake applied warning light
- 111 Central door locking control unit
- 112 Central locking control unit 15 A protective fuse
- 113 Electric front windows and electrically operated sun roof 25 A protective fuse
- 115 Electric front windows relay feed
- 116 Injection/ignition electronic control unit (I.A.W.)
- 118 Connection for cables signalling right front door ajar
- 119 Right front speaker wiring
- 120 Front courtesy light push button on right front pillar
- 121 Switch signalling seat belts not fastened
- 122 Right front electric window motor
- 125 Left front door locking motor
- 126 Push button signalling left front door ajar
- 127 Rear courtesy light push button on left centre pillar
- 129 Left rear door locking motor
- 130 Push button signalling left rear door ajar
- 134 Left rear courtesy light
- 136 Heated rear windscreen
- 141 Fuel level gauge and reserve warning light control
- 142 Electric fuel pump
- 143 Right front door locking motor

144 Push button signalling right front door ajar
 145 Push button for rear courtesy light on right centre pillar
 147 Right rear door locking motor
 148 Push button signalling right rear door ajar
 149 Longitudinal accelerometer for anti-lock brakes
 150 Transverse accelerometer for anti-lock braking system
 151 Left rear light cluster
 153 Rear earth cable loom
 155 Number plate lights
 156 Reversing lights
 158 Earth cable loom on tailgate
 159 Rearscreen wash/wipe
 160 Right rear light cluster
 161 Right rear courtesy light
 162 Luggage compartment courtesy light
 163 Electric windscreen washer pump
 164 Electric pump for rearscreen washer
 166 Compressor pulley electro-magnetic coupling
 167 Air conditioner 10 A protective fuse
 168 Air conditioning system electro-magnet coupling relay feed
 171 Air conditioning system switch
 175 Idle pressure switch (anti-frost)
 176 Hydraulic control unit
 177 Anti-lock brakes relay circuit
 178 10 A protective fuse for anti-lock braking circuit
 179 Anti-lock braking system electronic control unit
 180 Sensor on left front wheel
 181 Sensor on right front wheel
 182 Sensor on right rear wheel
 183 Sensor on left rear wheel
 184 Switch on clutch pedal
 188 Connection for electrically operated sun roof cables
 189 Electrically operated sun roof switch
 190 Electrically operated sun roof ideogram light
 191 Electric sun roof control unit
 192 Geared motor for electrically operated sun roof
 193 Sun roof end of travel switch
 194 Connection for sun roof cables
 195 Connection for sun roof cables
 216 Earths on engine
 225 Anti-lock braking system cable coupling
 227 Left front direction indicator
 228 Right front direction indicator

231 Dipped beam headlamps remote control switch
 232 7.5 A protective fuse for rear fog lamps
 233 Engine cooling fan 2nd speed relay
 234 25 A protective fuse for engine cooling fan
 235 Current resistance restricter for engine cooling fan
 236 Impulse generator for speedometer signal
 246 Delay device for engine cooling fan
 247 Relay for switching off air conditioning compressor
 248 Thermistor for switching off air conditioning compressor
 249 Three stage pressure switch
 250 Connection for air conditioner front cables
 251 Connection for dashboard / air conditioner cables
 252 Connection for dashboard / air conditioner cables
 256 40A protective fuse for engine cooling fan
 257 Relay for car interior fan 1st speed
 258 Compressor switch
 259 Current stealer terminal
 260 Timing sensor
 261 Ignition unit
 262 Ignition coil unit
 263 Ignition coil unit
 264 Multiple relay
 265 Heated Lambda sensor
 266 Connection for heater/air conditioner cables

Cable colour code

A Light blue	CN Orange-Black
B White	GN Yellow-Black
C Orange	GL Yellow-Blue
G Yellow	GR Yellow-Red
H Grey	GV Yellow-Green
L Blue	HG Grey-Yellow
M Brown	HN Grey-Black
N Black	HR Grey-Red
R Red	HV Grey-Green
S Pink	LB Blue-White
V Green	LG Blue-Yellow
Z Violet	LN Blue-Black
AB Light blue-White	LR Blue-Red
AG Light blue-Yellow	LV Blue-Green
AN Light blue-Black	MB Brown-White
AR Light blue-Red	MN Brown-Black
AV Light blue-Green	NZ Black-Violet
BG White-Yellow	RB Red-White
BL White-Blue	RG Red-Yellow
BN White-Black	RN Red-Black
BR White-Red	RV Red-Green
BV White-Green	SN Pink-Black
BZ White-Violet	VB Green-White
CA Orange-Light blue	VN Green-Black
CB Orange-White	VR Green-Red
	ZB Violet-White