

**HYDRAULIC OPERATION**

- Diagram showing operation of hydraulic braking system and mechanical handbrake 1
- Pedal - Brake fluid reservoir 3
- Master cylinder 4
- Servo brake 6

**FRONT BRAKES**

- Removing-refitting 7
- Brake caliper 10
- Brake discs 11
- Brake pads - Bleeding - Replacing brake pads 12

**REAR BRAKES**

- Removing-refitting 13
- Brake caliper 16
- Device for the automatic adjustment of the clearance between the rear brake pads and disc and the handbrake 19
- Brake discs - Brake pads 21
- Load proportioning valve 22
- Bleeding - Handbrake 24

**TIGHTENING TORQUES**

DIAGRAM SHOWING HYDRAULIC OPERATION AND MECHANICAL HANDBRAKE FOR THE DELTA 4WD

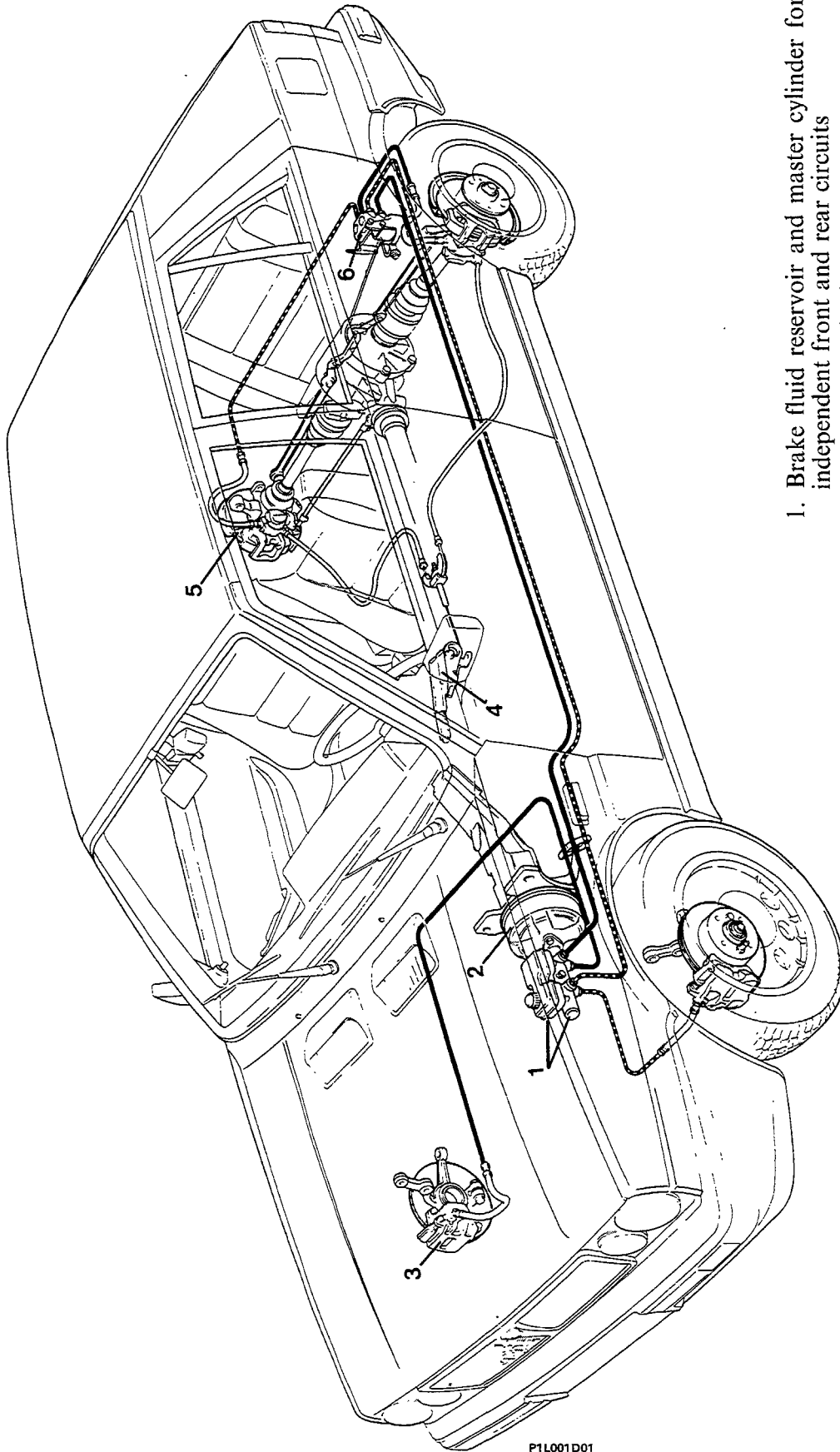

1. Brake fluid reservoir and master cylinder for independent front and rear circuits
2. Vacuum servo brake
3. Front disc brakes
4. Handbrake lever
5. Rear disc brakes
6. Load proportioning valve for rear brakes hydraulic circuit

— Hydraulic circuit for right front and left rear brakes

- - - Hydraulic circuit for left front and right rear brakes

P1L001D01

33.

DIAGRAM SHOWING HYDRAULIC OPERATION AND MECHANICAL HANDBRAKE FOR PRISMA 4WD

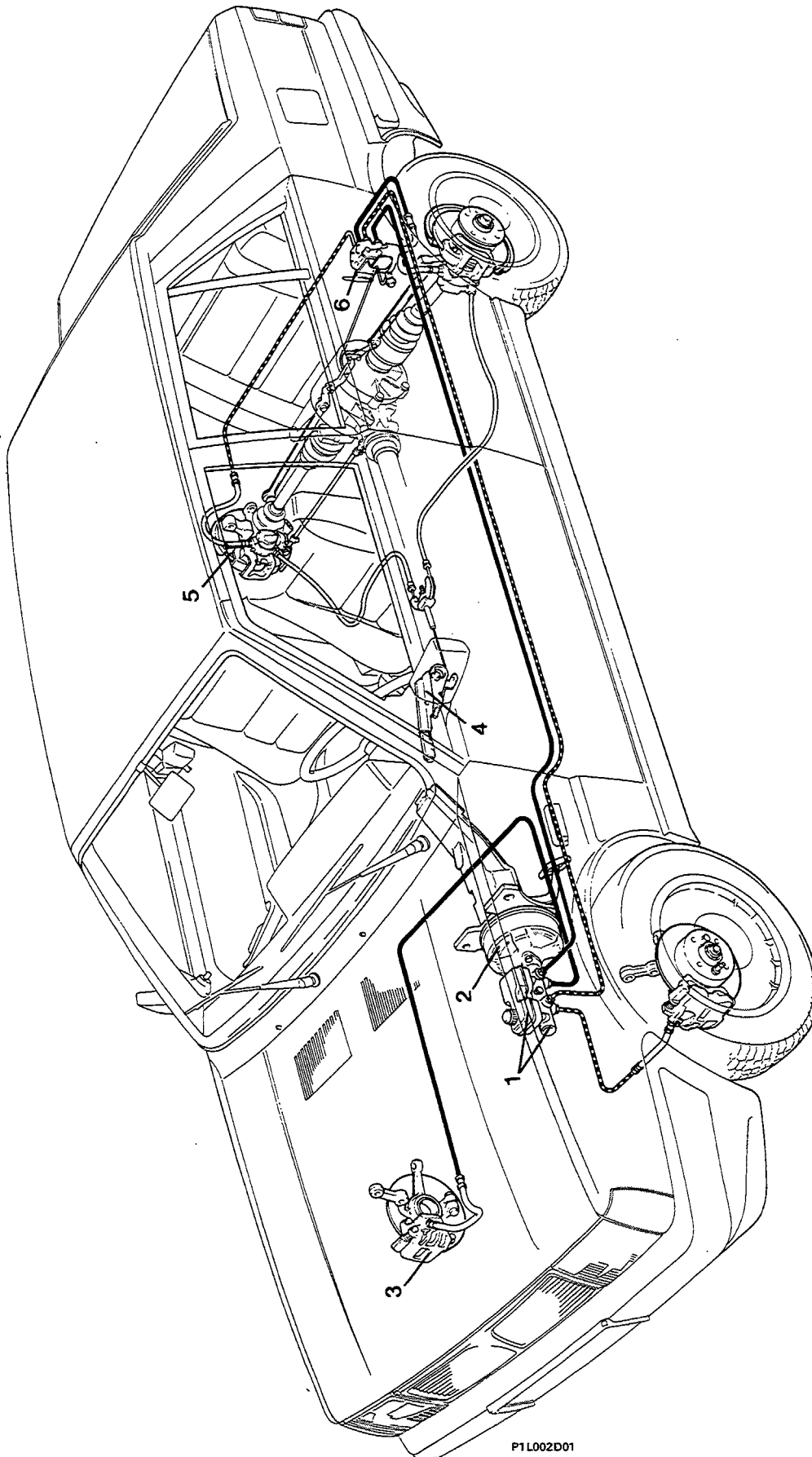

P1L002D01

1. Brake fluid reservoir and master cylinder for independent front and rear circuits
2. Vacuum servo brake
3. Front disc brake
4. Handbrake lever
5. Rear disc brake
6. Load proportioning valve for rear brakes hydraulic circuit

— Hydraulic circuit for right front and left rear brakes

- - - Hydraulic circuit for left front and right rear brakes

### PEDAL

#### Removing-refitting brake pedal

In order to remove the brake pedal the nut shown by the arrow has to be undone after having previously removed the clutch cable and the pedal.

Remove the pedal mounting pin and release the brake pedal from the servo brake push rod.



*the parts concerned with grease before fitting.*

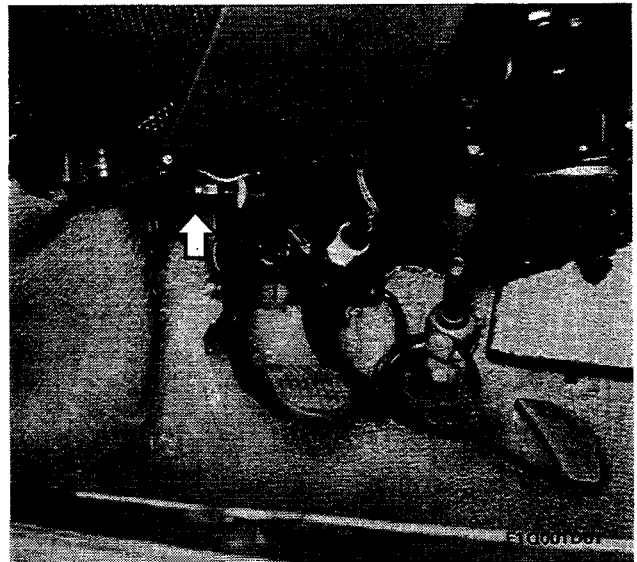

### BRAKE FLUID RESERVOIR

#### Checking insufficient brake fluid level warning device

**NOTE** *Periodically check the operation of the warning device by pressing on the top of the brake fluid reservoir cover (as shown by the arrow); with the ignition switch in the "ON" position the warning light should come on.*

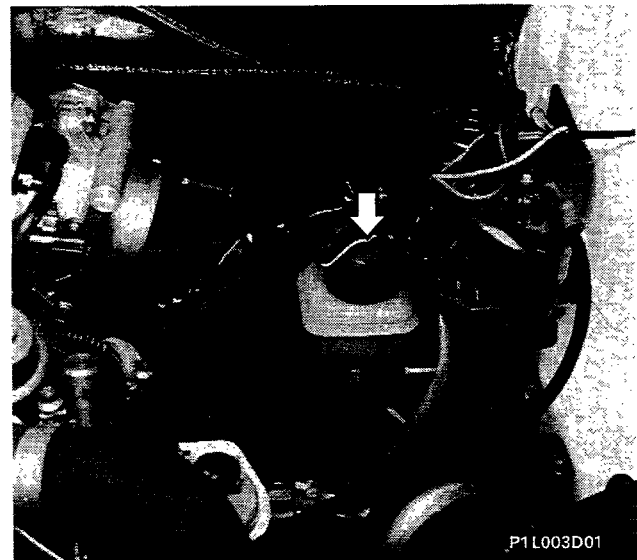

#### Removing-refitting reservoir from master cylinder

In order to gain access to the reservoir the power assisted steering fluid reservoir and the coil assembly have to be removed.



*Before removing the reservoir drain the brake fluid.*



*Bleeding hydraulic system.*



**33.**



**MASTER CYLINDER**



**Removing-refitting brake pipes and master cylinder**

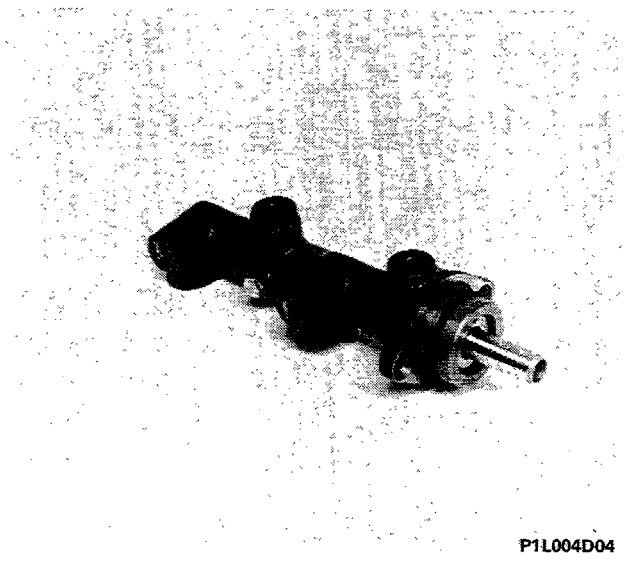

**Removing-refitting master cylinder**



*Bleeding braking system*

**Master cylinder assembly removed from vehicle**

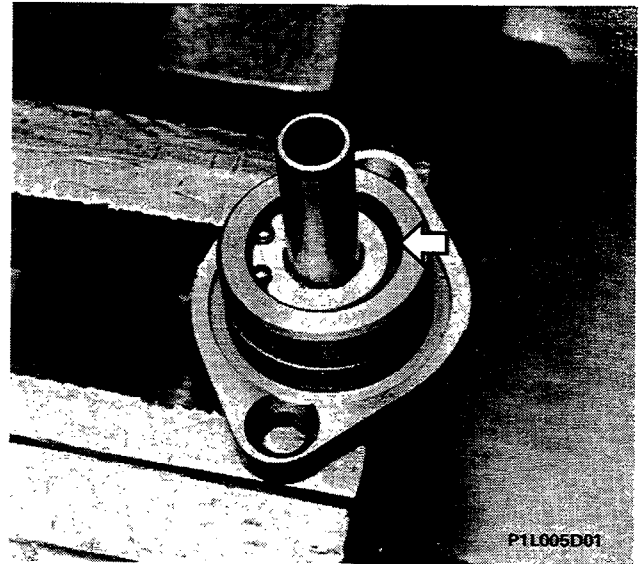

Removing-refitting master cylinder internal assembly circlip

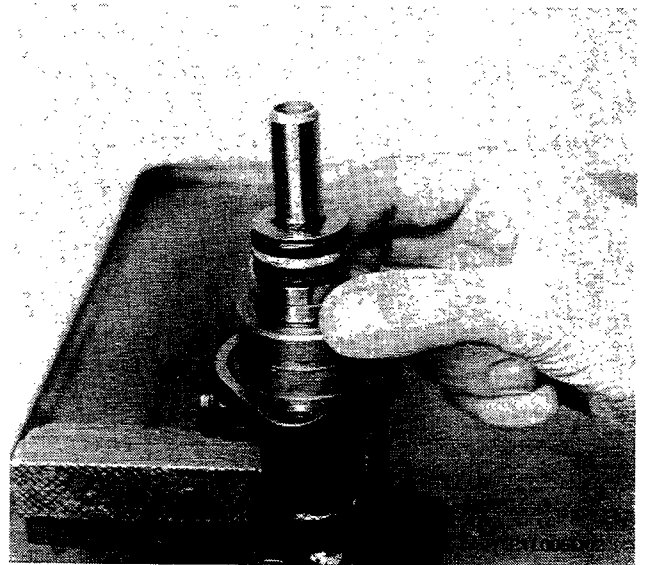

Removing-refitting master cylinder internal assembly

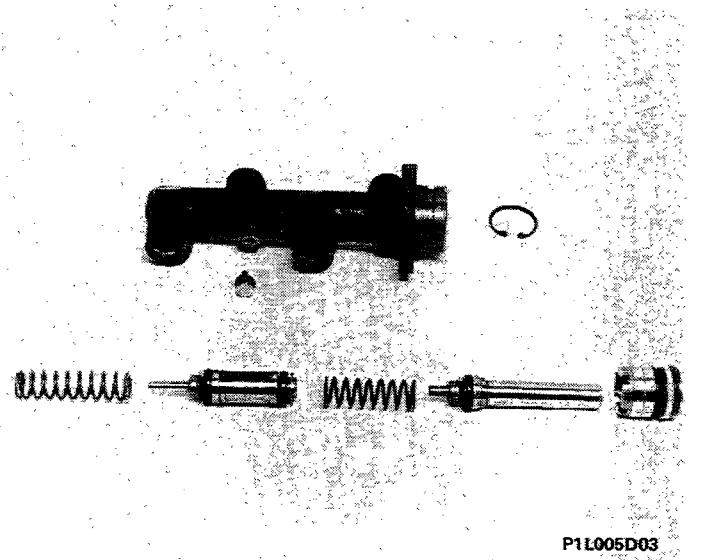

### Master cylinder assembly components

When overhauling, always replace the seals; if any traces of abrasion or seizing are noticed on the master cylinder casing the assembly must be replaced.

33.

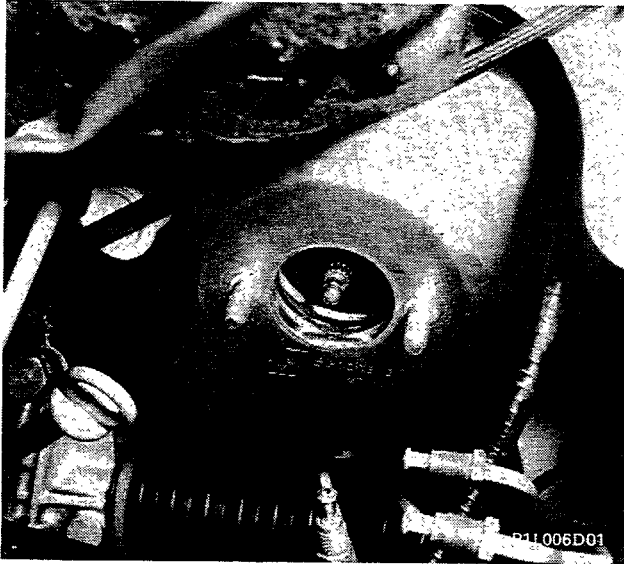

SERVO BRAKE

Servo brake fitted on vehicle

**NOTE** *The servo brake is adjusted using the adjustment screw at the end of the rod. In the rest position the end of the adjustment screw should be recessed in relation to the plane of the front cover by 0.3 - 0.5 mm.*

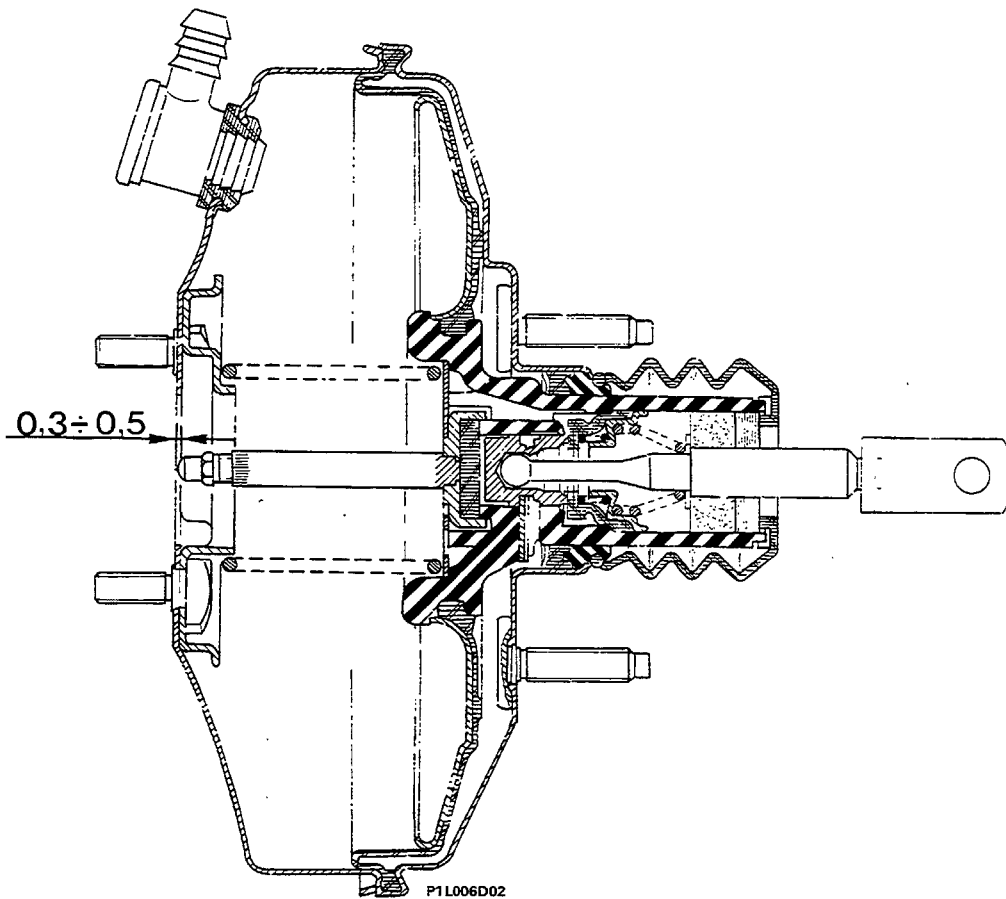

Longitudinal section of servo brake

REMOVING-REFITTING

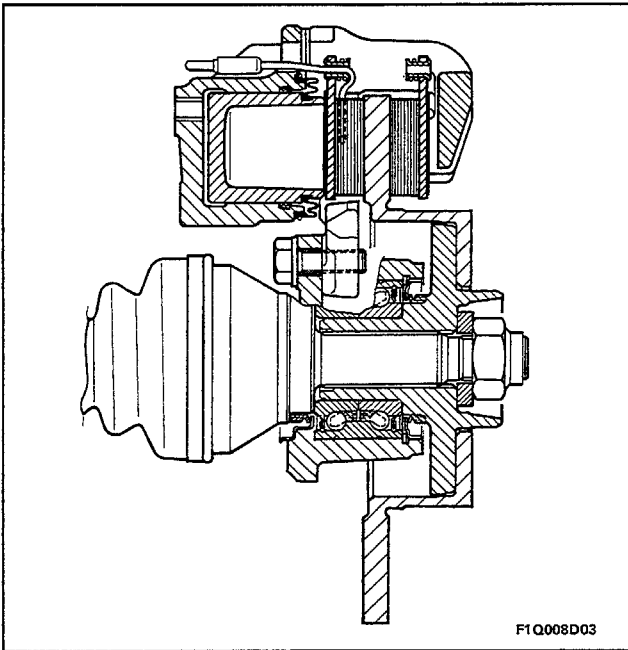

F1Q008D03

Cross section of front brake caliper and wheel hub

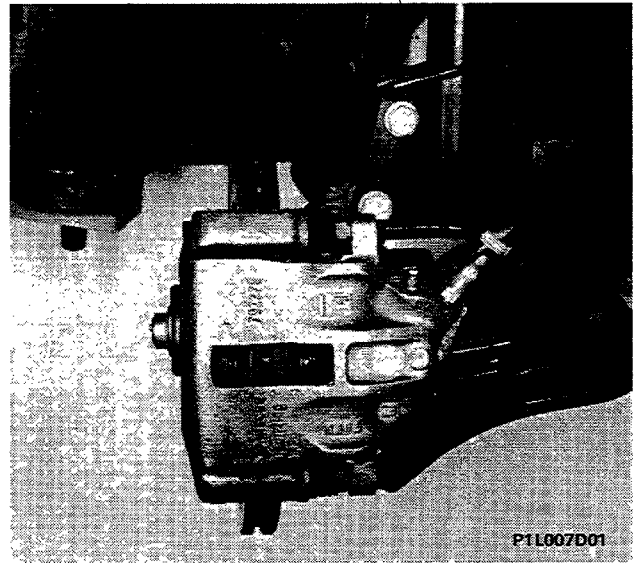

P1L007D01

Front brake assembly fitted on vehicle



P1L007D03

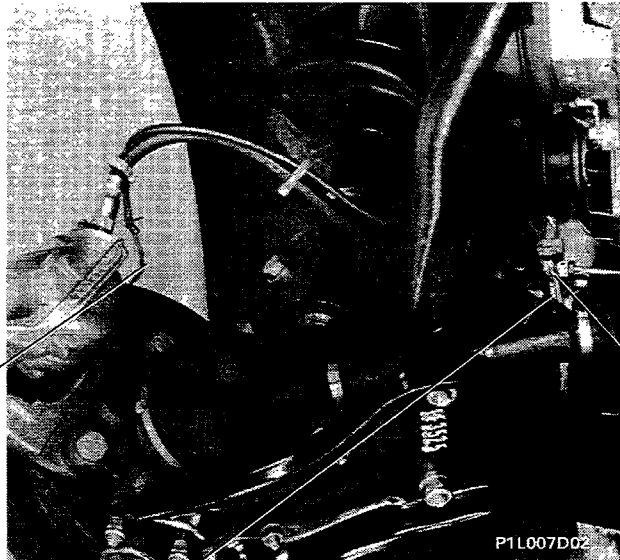

P1L007D02

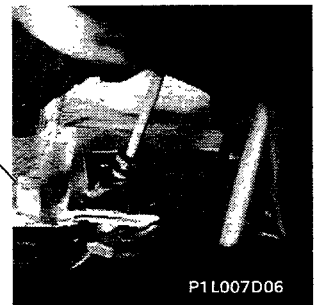

P1L007D06



P1L007D04

Removing-refitting flexible pipe and electrical connection from brake pad



1856132000

P1L007D05



### 33.

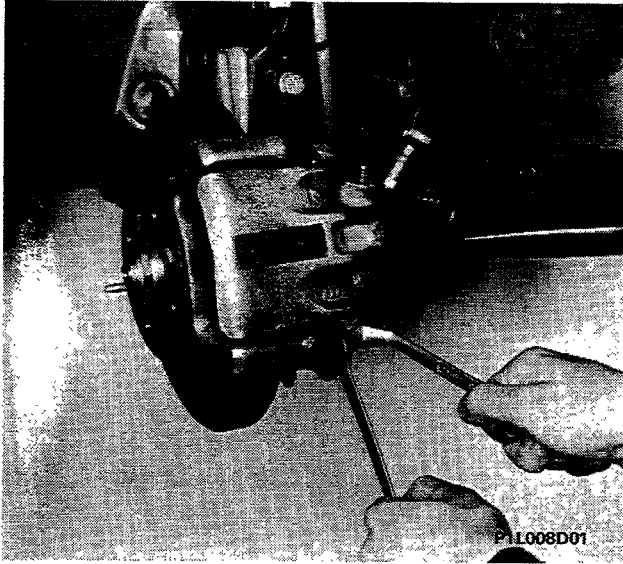

#### Removing-refitting brake caliper self-locking bolts



*The bolts fixing the brake caliper are self-locking and must always be replaced each time they are loosened or undone.*

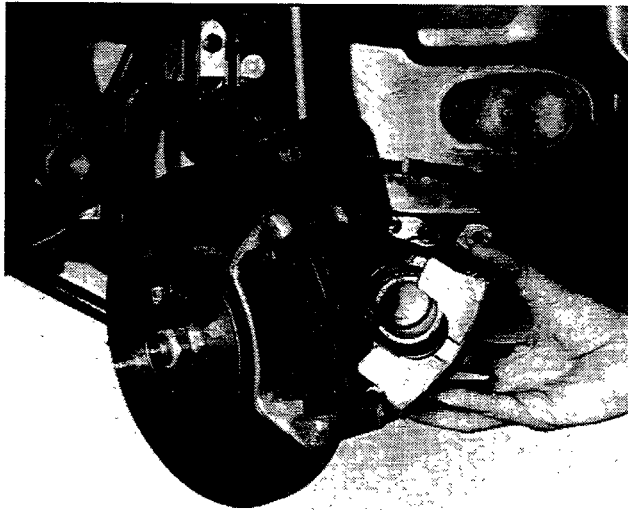

#### Removing-refitting brake caliper

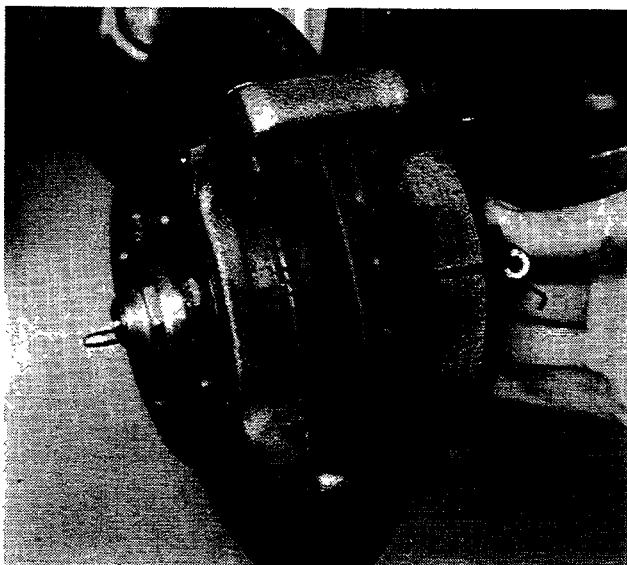

#### Removing-refitting brake pads

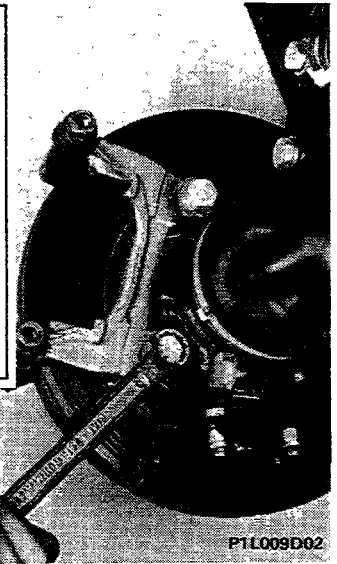
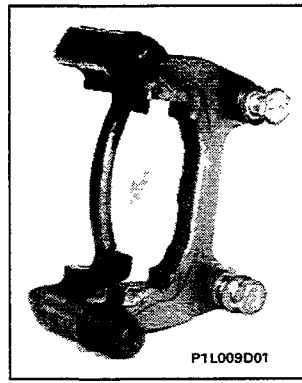

**Removing-refitting caliper support bracket**



*Before refitting the caliper support bracket, check that the rubber boots are intact; if they are not, they must be replaced.*

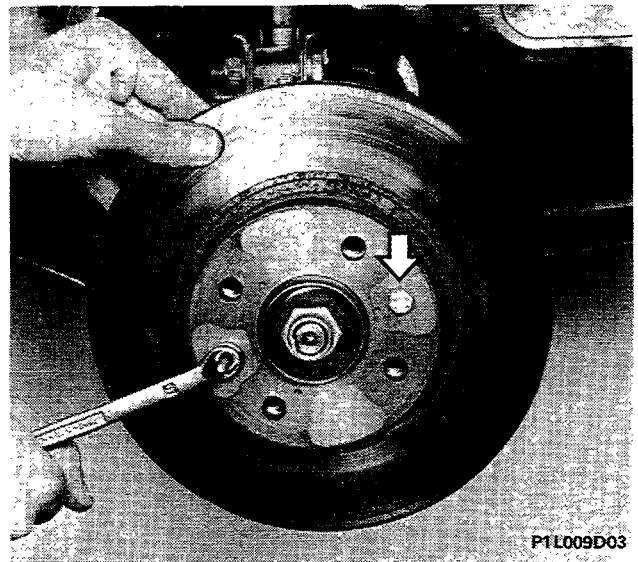

**Removing-refitting brake disc fixing bolts**

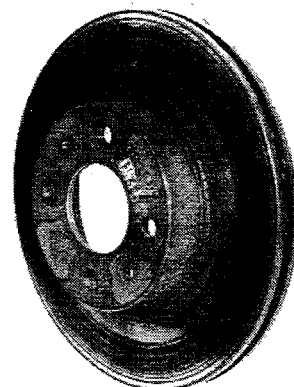
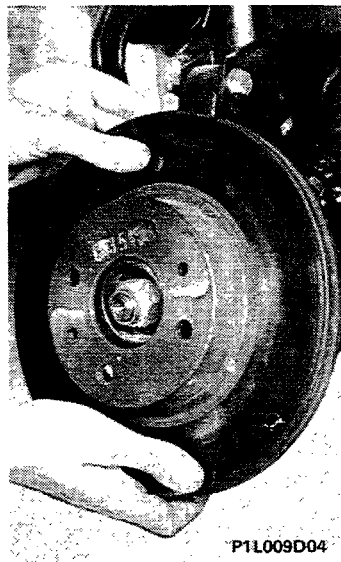

**Removing-refitting brake disc**

When refitting, remove any possible traces of rust to ensure that the disc is perfectly perpendicular in relation to the hub.

### 33.

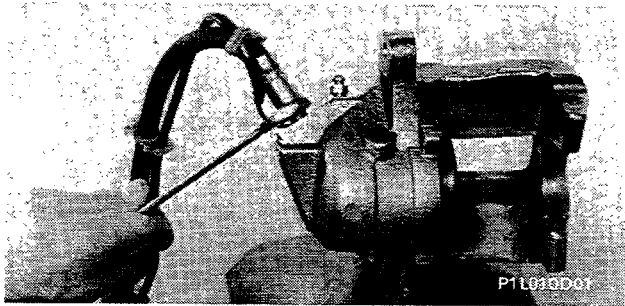

#### BRAKE CALIPER

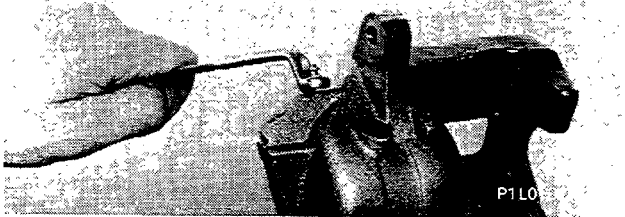

#### Removing-refitting flexible pipe union and bleed screw

**NOTE** *The flexible pipe should not show any signs of bulges or cracks or else it must be replaced.*

*It is advisable to replace both pipes.*

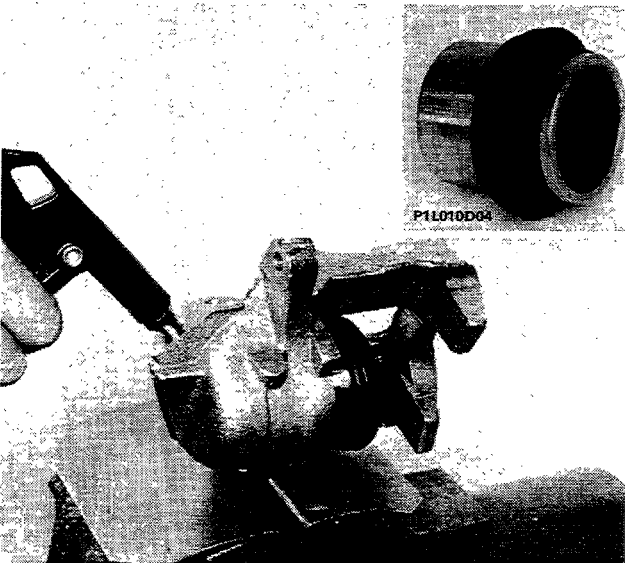

#### Removing piston and protective boot and checking caliper assembly components



The piston casing is removed by directing a jet of compressed air into the brake fluid inlet opening.

The piston and the caliper casing should not show any signs of abrasion or seizing; if they do, the entire caliper must be replaced.

The protective boot and the seal must be replaced each time also making sure that the bleed screw is not obstructed.



*A solution of warm water and FIAT LDC detergent should be used to wash the metal components.*

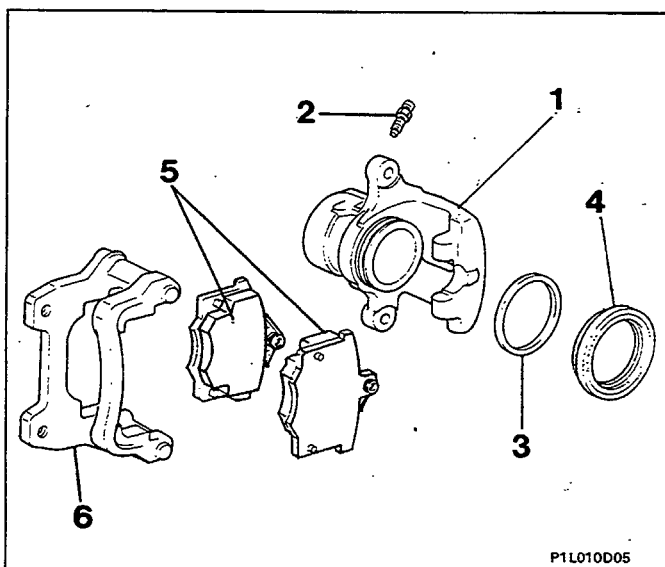

#### Exploded view of brake caliper

1. Caliper casing
2. Bleed screw
3. Seal
4. Protective boot
5. Brake pads
6. Caliper support bracket



### Fitting seal and piston on caliper casing



*the parts concerned with brake fluid before fitting.*

### BRAKE DISCS

#### Checking and measuring disc

The minimum allowable thickness for brake discs due to wear is 10.8 mm for the Prisma 4WD and 18.2 mm for the Delta 4WD; if the brake disc measures less than this then it must be replaced.

In the case of deterioration or deep grooves, the surfaces of the brake disc should be refaced using a grinder; when the operation is completed the thickness of the brake disc should not be less than 11.3 mm for the Prisma 4WD and 18.55 for the Delta 4WD.

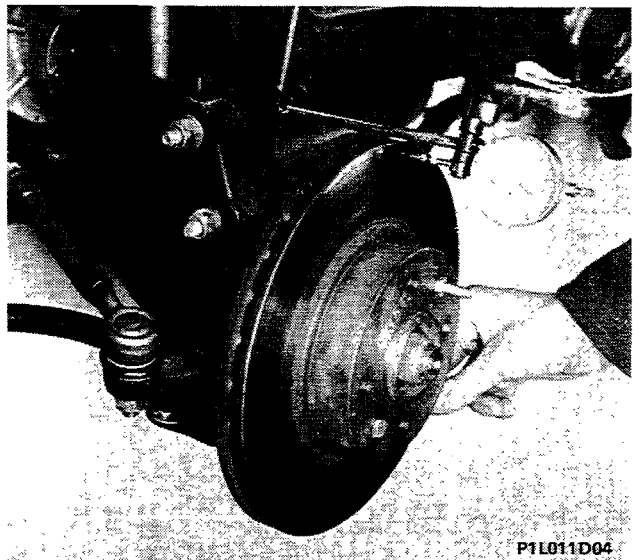
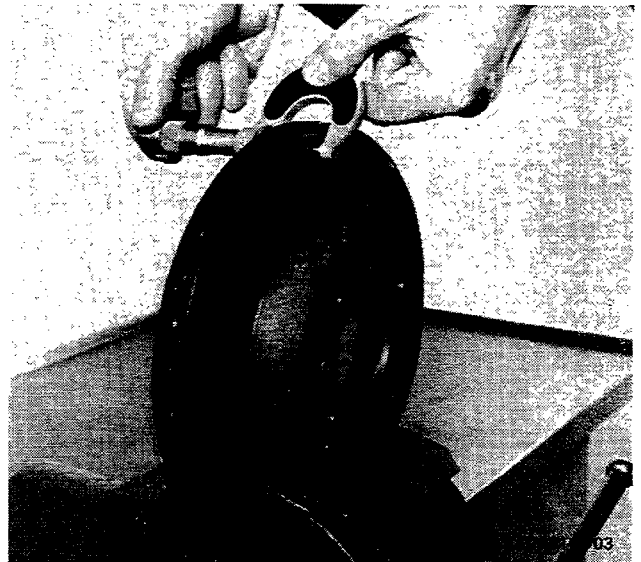

#### Checking run out of brake disc

If the brake pads have to be replaced, it is advisable to check that the disc is no more than 0.15 mm off centre.

This is measured 2 mm from the external diameter of the disc.

### 33.

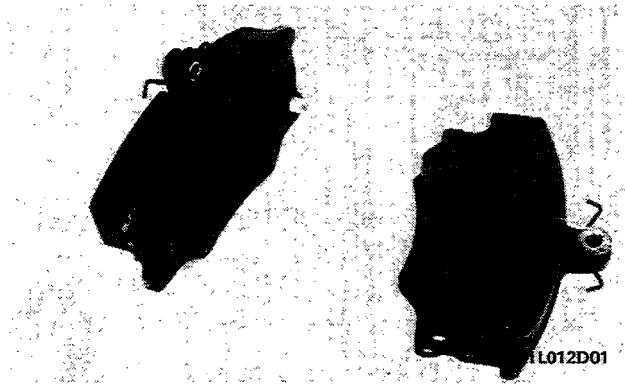

#### BRAKE PADS

##### Checking brake pads

The brake pads must be replaced when the thickness of the lining is less than 1.5 mm. Check that the same type of pads are fitted on each pair of wheels.

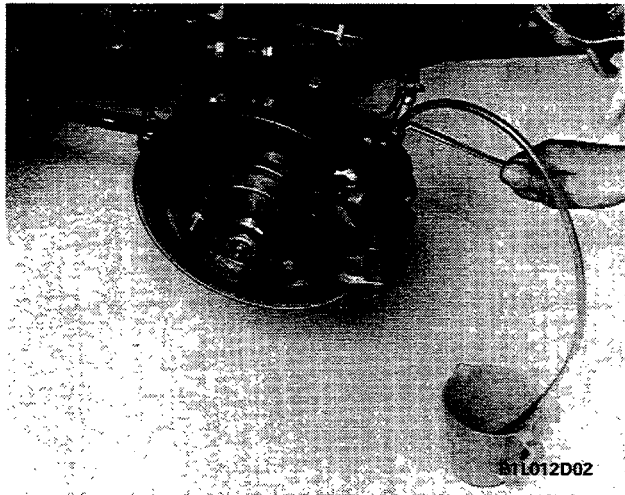

#### BLEEDING

It is not advisable to reuse the brake fluid collected. The reservoir should be topped up with new brake fluid.

#### REPLACING BRAKE PADS

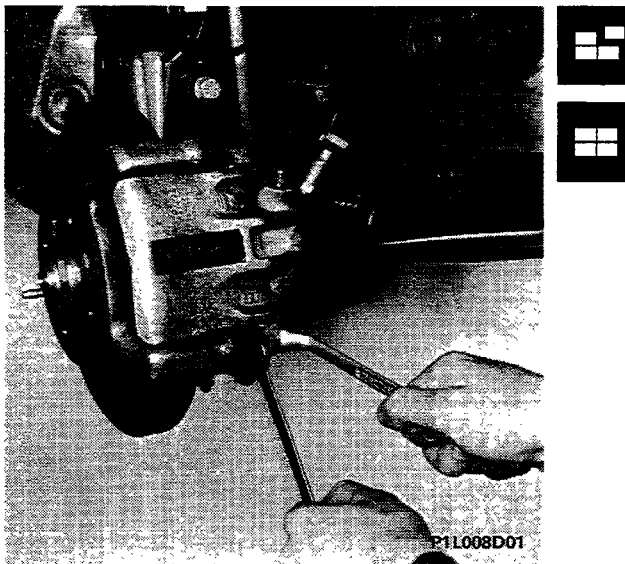

If only the brake pads are being replaced, the flexible pipe does not have to be removed.



*The bolts fixing the caliper casing are self-locking and must always be replaced each time they are loosened or undone.*



*Bleeding hydraulic system.*

**REMOVING-REFITTING**

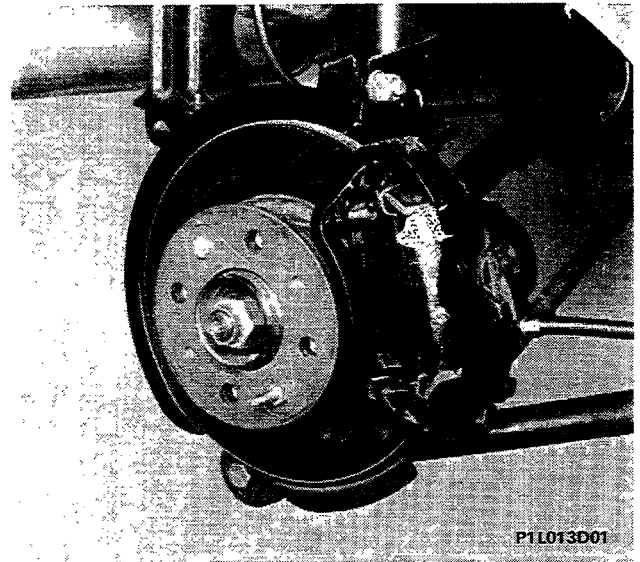

**Rear brake assembly fitted on vehicle**

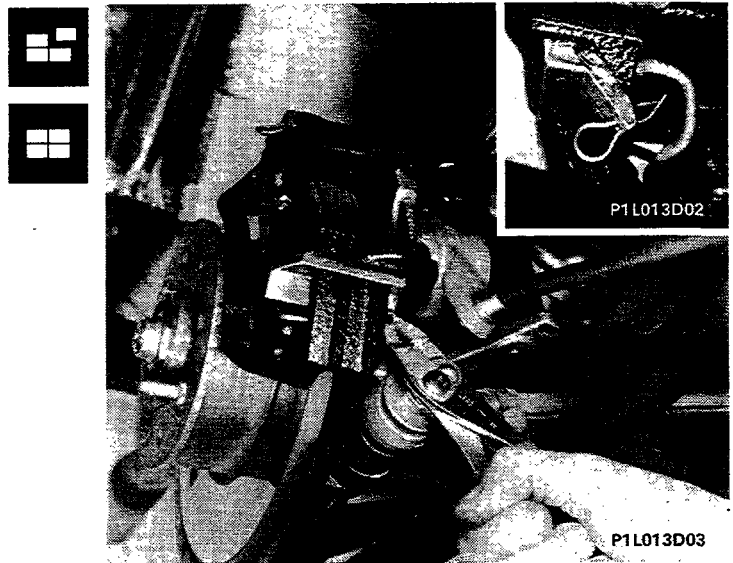

**Removing-refitting sliding pad split pins**

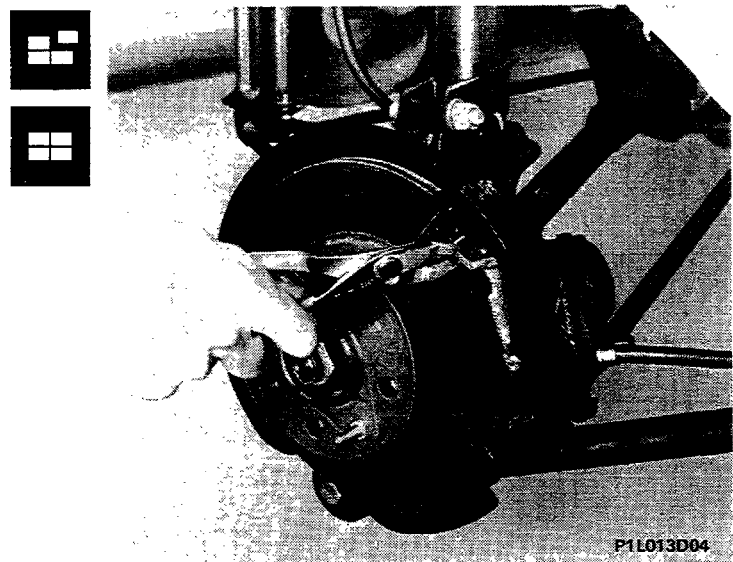

**Removing-refitting sliding pads**

33.

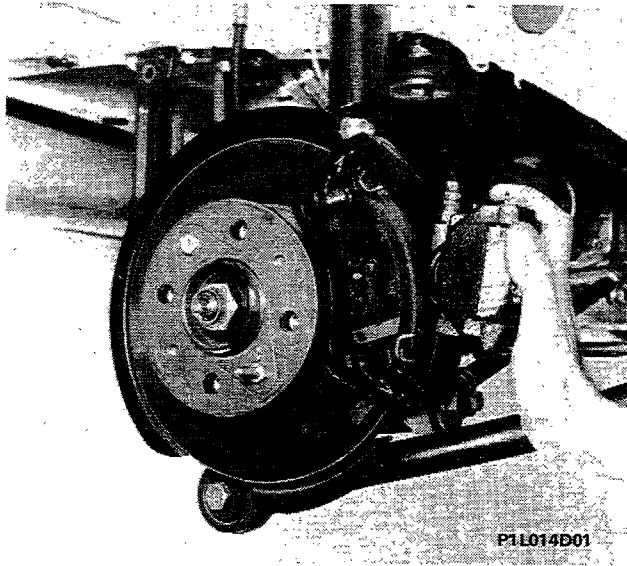

**Removing-refitting brake caliper from support bracket**

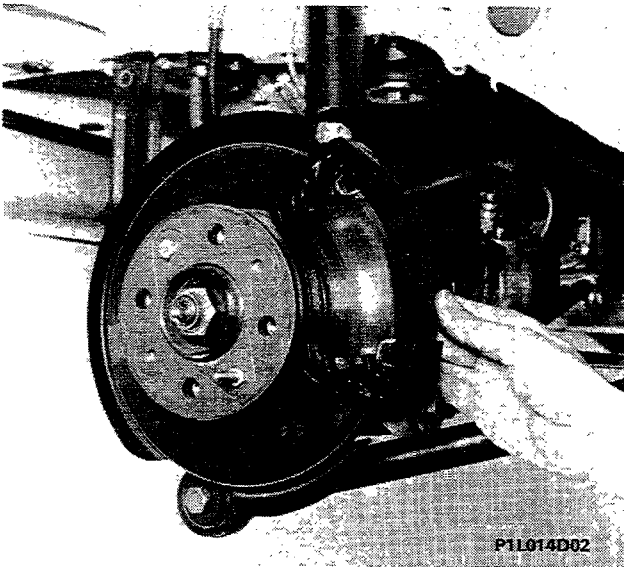

**Removing-refitting brake pads**

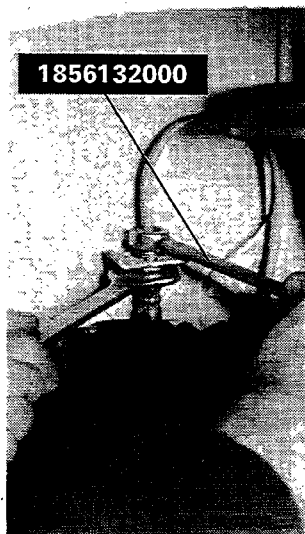
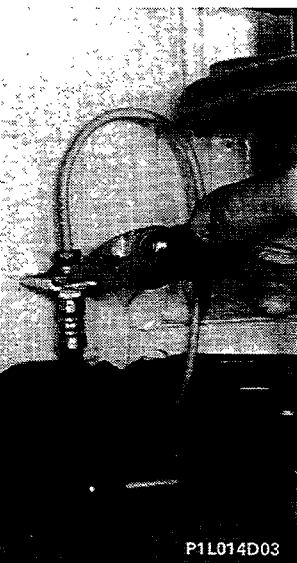

**Removing-refitting flexible pipe**

If only the brake pads are being replaced then the flexible pipe does not have to be removed.

**Removing-refitting brake caliper**

Before proceeding to remove-refit the brake caliper, the handbrake cable has to be released from the actual caliper.



P1L015D01



P1L015D02

**Removing-refitting nut fixing transverse rod**

In order to gain access to the caliper support bracket bolts, the nut fixing the transverse rod has to be removed and the rod moved away from the stub axle.

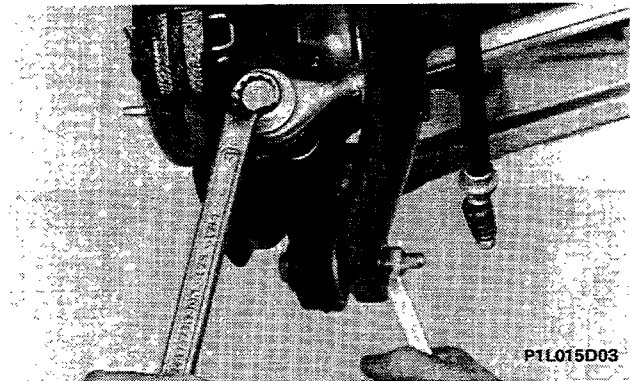

P1L015D03



P1L015D04

**Removing-refitting brake caliper support bracket**

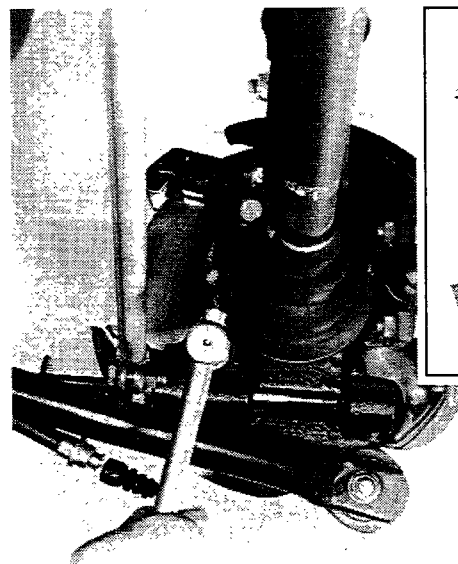

P1L015D06

P1L015D05



### 33.

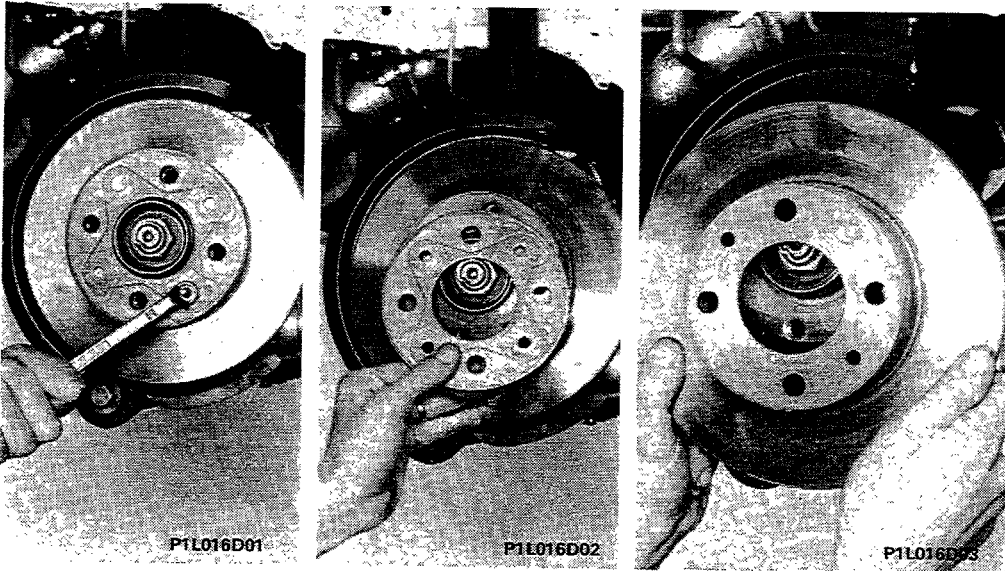

#### Removing-refitting brake disc from hub

When refitting, remove any possible traces of rust to ensure that the disc is perfectly perpendicular in relation to the hub.

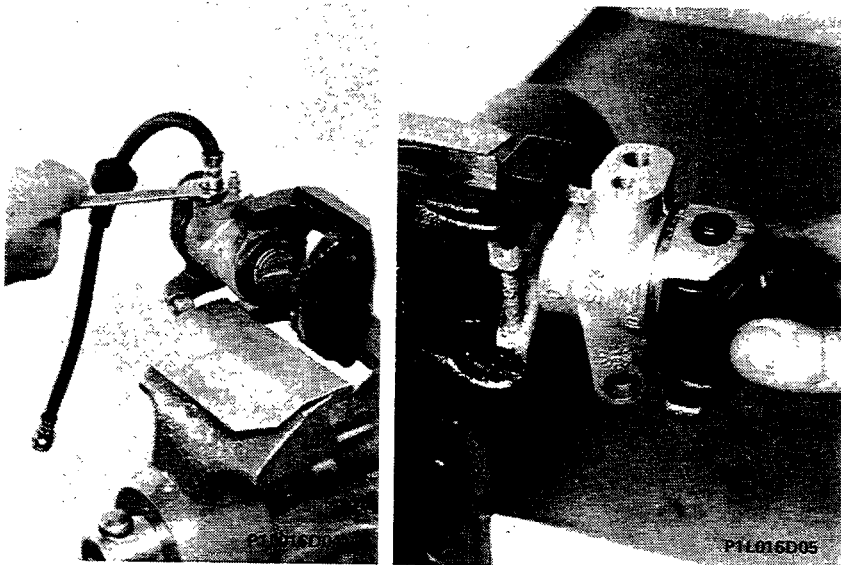

#### BRAKE CALIPER

#### Removing-refitting flexible pipe and bleed screw and removing protective boot

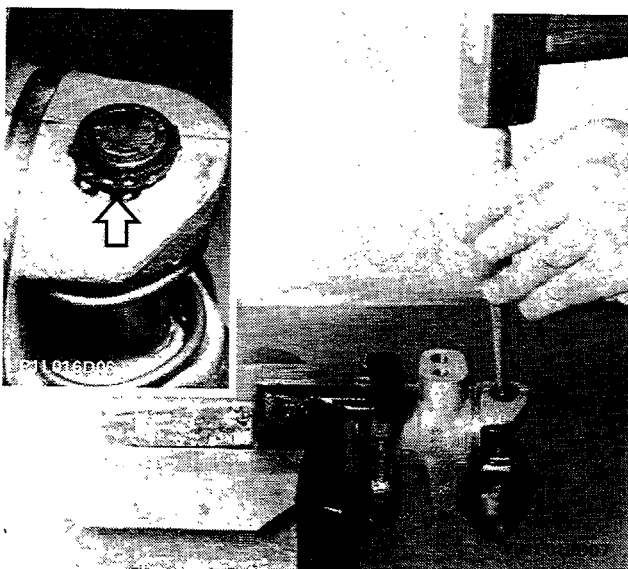

#### Removing-refitting handbrake control from bra- ke caliper

Before removing the device pin, the circlip shown by the arrow has to be removed.

Handbrake components

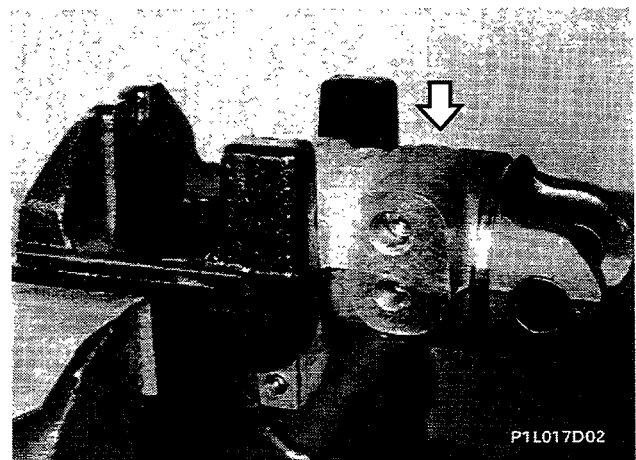
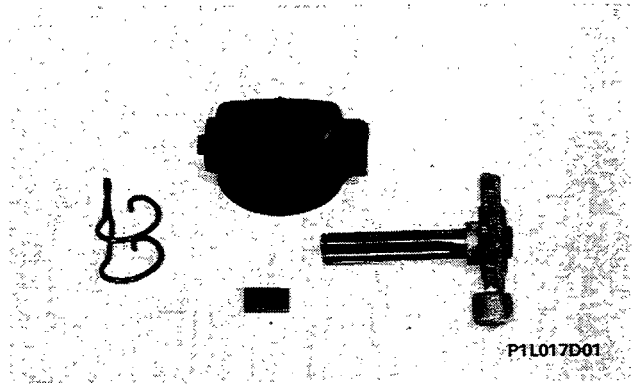

Removing-refitting cylinder support from caliper casing

In order to proceed with the removal of the cylinder support from the caliper casing the retaining pin has to be released using a point as illustrated in the diagram.

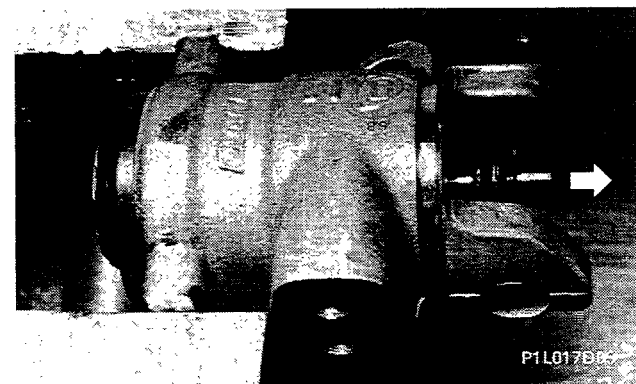
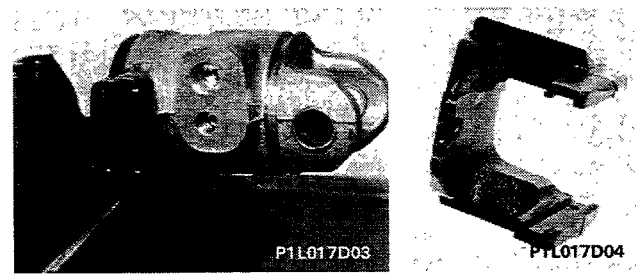

Removing-refitting device adjusting clearance between brake pads and brake disc

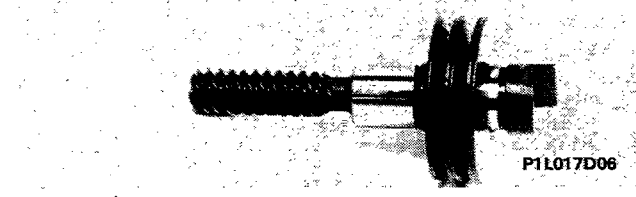

**33.**

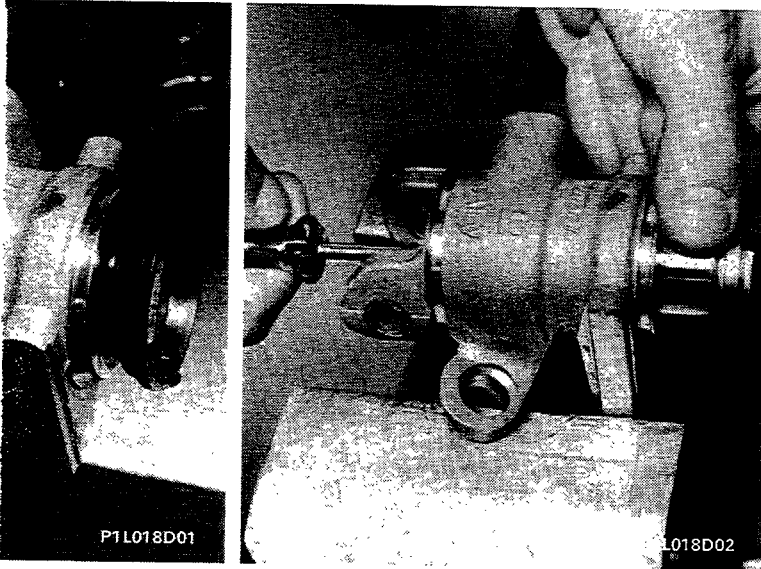

**Removing-refitting protective boot and piston**

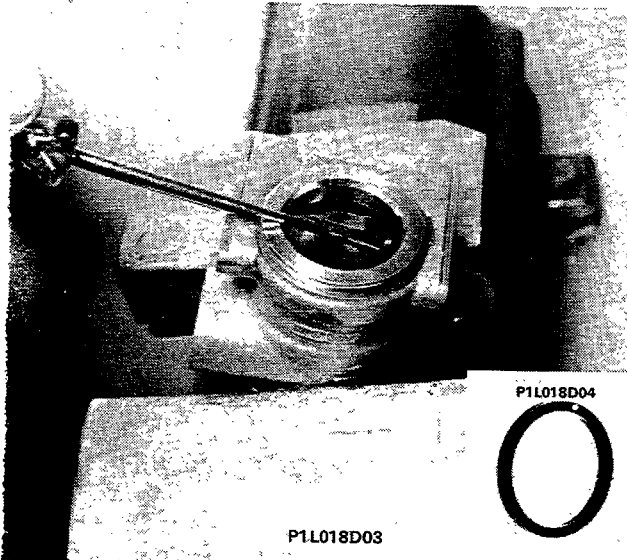

**Removing-refitting seal**

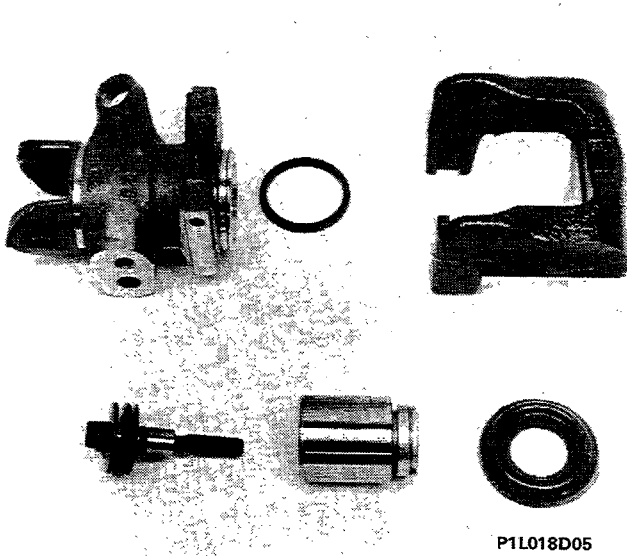

**Brake caliper components**

**Fitting piston and dust cover in caliper casing**



*the parts concerned with brake fluid before fitting.*



*The reference mark on the piston (shown by the arrow) should be parallel to the surface of the bleed screw and turned towards it.*

*If this procedure is not followed it results in the malfunction of the braking system because it is not possible to bleed the system effectively.*

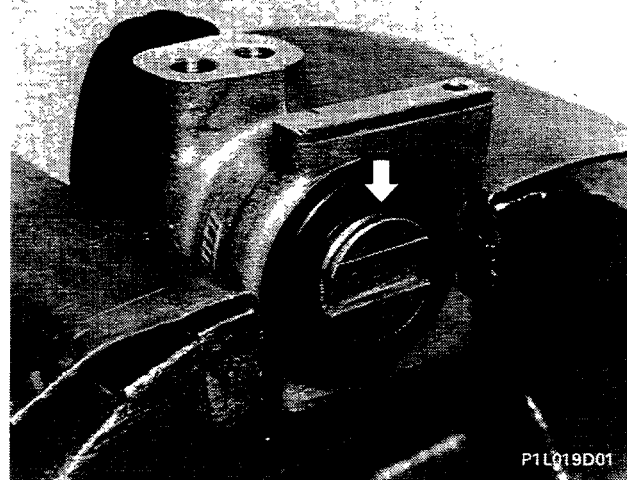

**AUTOMATIC DEVICE FOR ADJUSTING THE CLEARANCE BETWEEN THE REAR BRAKE PADS AND DISCS AND THE HANDBRAKE**

**Operation**

The rear brake caliper piston contains a device which allows the distance between the brake discs and pads to be adjusted automatically.

This device comprises a spring (3), a self-adjustment female thread screw (4), a bearing (5), a plate (12), a clip (11) and a five-start threaded pin for self-adjustment (6).

In the rest position the position of the self-adjustment device, in relation to the piston (1), is shown in fig. A. Whilst braking, the piston (1) moves in the cylinder assuming the position illustrated in fig. B, allowing the brake pads to make contact with the disc; the piston travel therefore corresponds to clearance G1 between the bearing (5) and the plate (12) fixed by the clip (11).

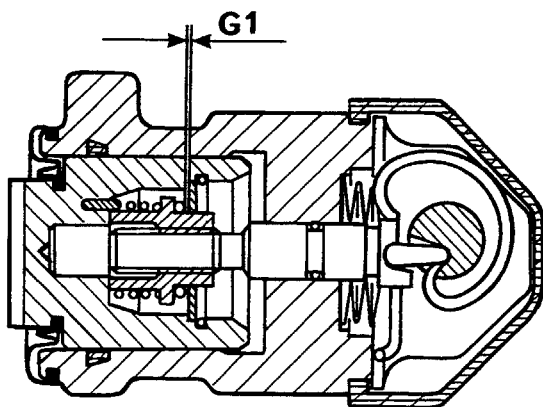

Fig. A

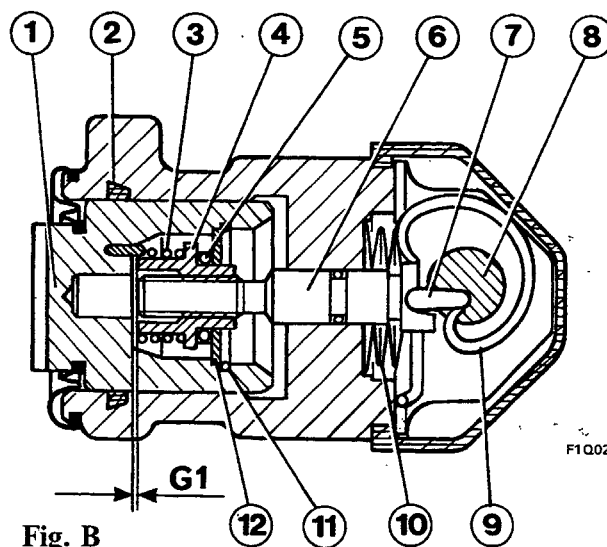

Fig. B

F1Q022D02

**Cross section of rear brake caliper cylinder**

- |  |                                    |
|--|------------------------------------|
| 1. Piston                                  | 7. Plate for piston with handbrake |
| 2. Piston seal                             | 8. Plate (7) control lever shaft   |
| 3. Spring for female thread screw          | 9. Spring for shaft (8)            |
| 4. Female thread screw for self-adjustment | 10. Flexible washer                |
| 5. Ball bearing                            | 11. Clip                           |
| 6. Pin for self-adjustment                 | 12. Plate                          |

### 33.

After the sliding of the piston the seal (2) is distorted.

If the distance between the brake pads and the brake disc is greater than clearance  $G1$ , because the pads are worn, then the piston moves further into the cylinder forcing the female thread screw (4) to rotate in a clockwise direction on the threaded pin (6) by means of the plate (12).

During this rotation, the spring (3) turns in an anti-clockwise direction on the female thread screw and fixed to the piston at one end it tends to unwind allowing the female thread screw to rotate.

Once the braking action is over, the piston recedes under the action of the seal (2) which resumes its original shape.

However, the return stroke of the piston is always equal to the value of clearance  $G1$  as it will stop when it makes contact with the female thread screw (4) as shown in fig. A.

In its turn the female thread screw cannot recede because in order to do this it would have to rotate in the same direction as the spring (3) is wound but the friction between the spring and the screw is such that the latter remains fixed in position. In this way whatever the wear to the pads, obviously assuming it is within the permissible limits, the exact clearance between the pads and the disc is automatically renewed; the handbrake is also adjusted at the same time since the shaft (8), controlled by the handbrake lever, acts directly on the pin (6) via the plate (7).

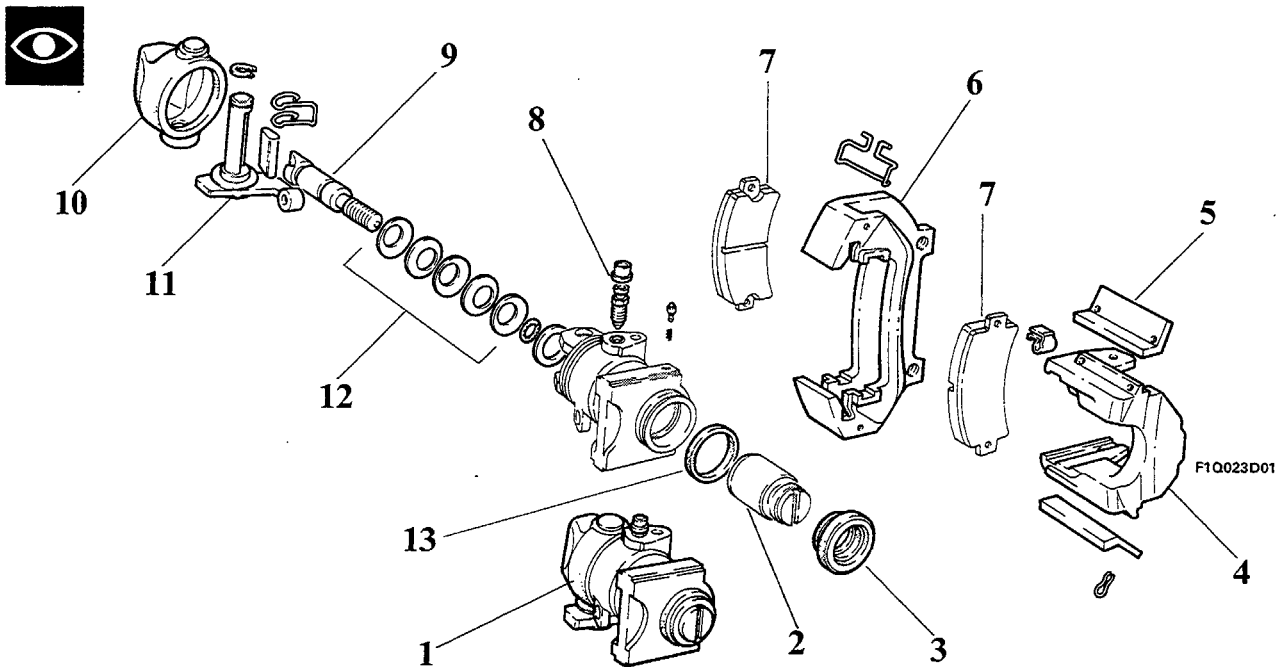

**Brake caliper assembly components**

- |                            |  |
|----------------------------|--|
| 1. Caliper casing          | 8. Bleed screw                               |
| 2. Piston                  | 9. Pin for self-adjustment                   |
| 3. Dust cover              | 10. Protective boot                          |
| 4. Cylinder mounting       | 11. Lever with pin for controlling handbrake |
| 5. Sliding pads            | 12. Flexible washers                         |
| 6. Caliper support bracket | 13. Piston seal                              |
| 7. Brake pads              |  |

**NOTE** *The piston and the caliper casing should not show any signs of abrasion or seizing; if this is not the case then the complete caliper must be replaced.*



*Use a solution of warm water and FIAT LDC detergent to wash the metal components.*

### BRAKE DISCS

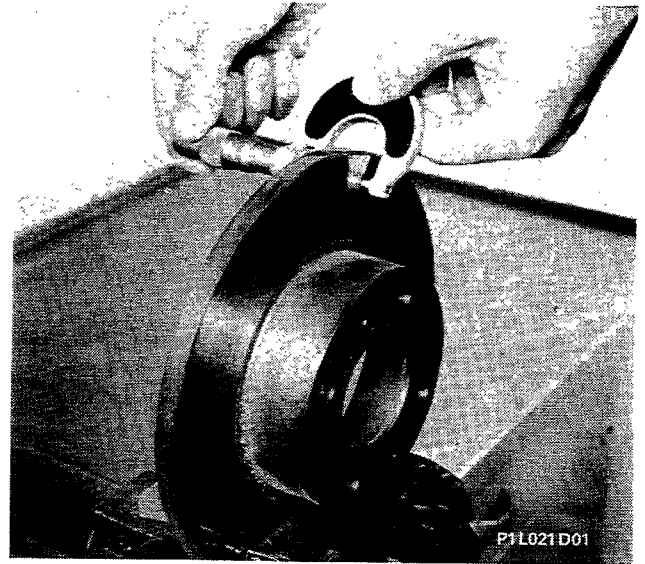

P1L021D01

#### Checking and measuring brake disc

The minimum allowable thickness for brake discs is 9 mm; if it measures less than this, the disc must be replaced.

In the case of wear or deep grooves, the surfaces of the brake disc can be machined. After grinding the brake disc must not be less than 9.7 mm thick.

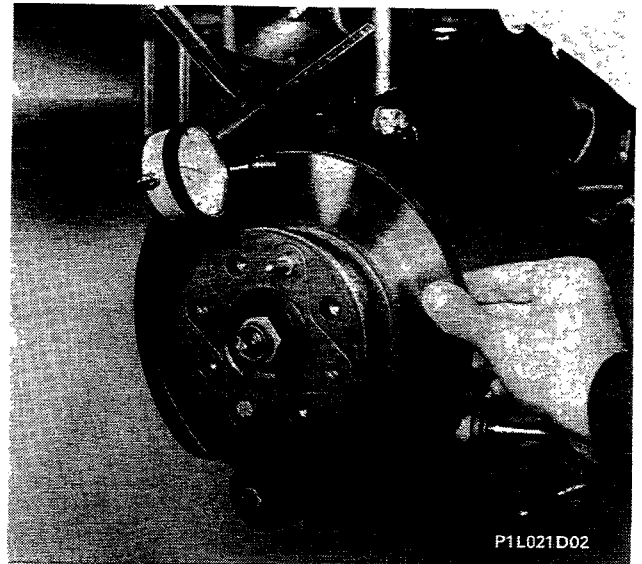

P1L021D02

#### Checking run out of brake disc

If only the brake pads have to be replaced, it is advisable to check that the disc is no more than 0.15 mm off centre.

This is measured 2 mm from the external diameter of the disc.

### BRAKE PADS



P1L021D03

#### Checking brake pads

The brake pads must be replaced when the thickness of the lining is less than 1.5 mm.

Check that the same type of pads are fitted on each pair of wheels.

**33.**

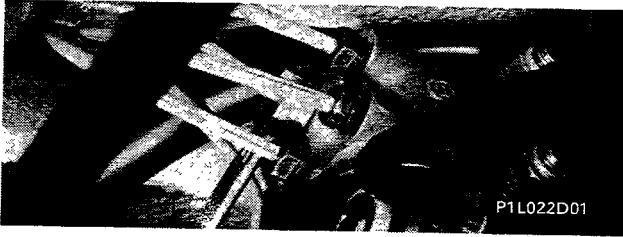

**LOAD PROPORTIONING VALVE**  
Removing-refitting

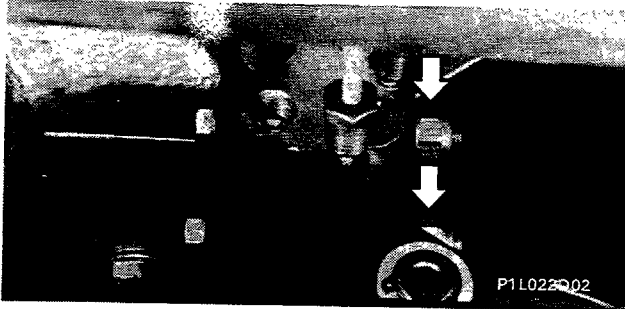

**Removing-refitting unions and nuts fixing load proportioning valve to mounting**

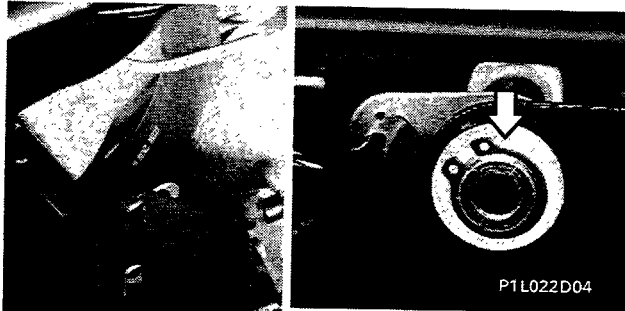

**Removing-refitting bar mounting pin from load proportioning valve**

In order to remove the bar mounting pin, the circlip shown by the arrow in the diagram has to be removed.



**Removing-refitting bar from mounting after having removed circlip**



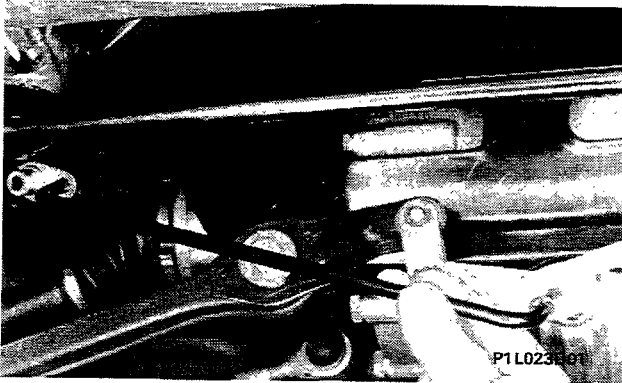

Removing-refitting bar



Removing-refitting load proportioning valve



Bleeding hydraulic system

The load proportioning valve for the rear wheels, fixed to the rear suspension transverse rods cross member, differentiates between the pressure in the rear brake circuit and the pressure in the front circuit according to the vehicle load and deceleration conditions.

The variation in pressure is caused by the position which the bar connected to the rear suspension transverse rods which acts on the load proportioning valve piston assumes.

### Cross section of load proportioning valve

1. Seat for rear brake pipe unions
2. Seat for front brake pipe unions
3. Dust cover
4. Piston

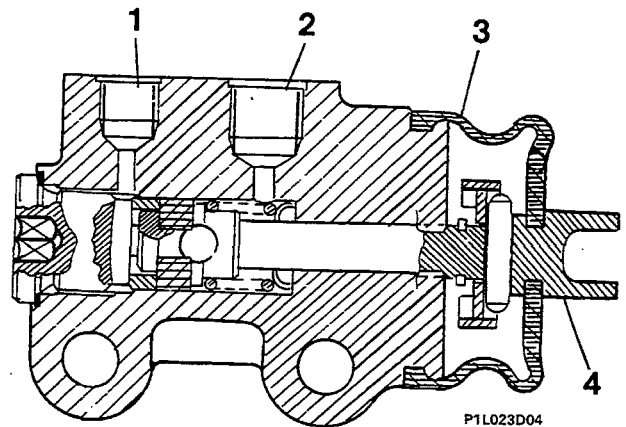

### Adjusting load proportioning valve

- Raise the vehicle at the back;
- loosen the load proportioning valve fixing bolts;
- bring point F of the load proportioning valve to distance B from end A of the bar;
- then lock the fixing bolts.

Distance B =  $1.1 \pm 0.2$  mm

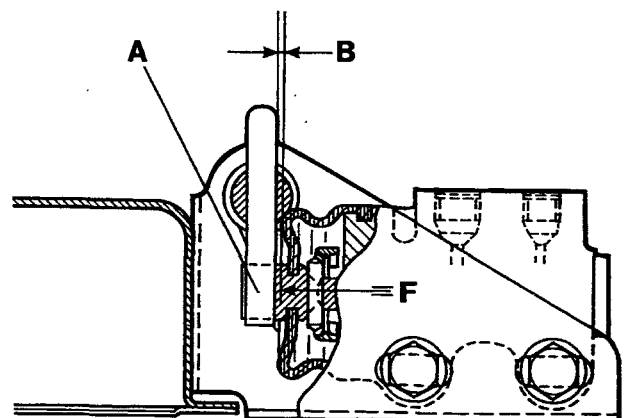



### 33.

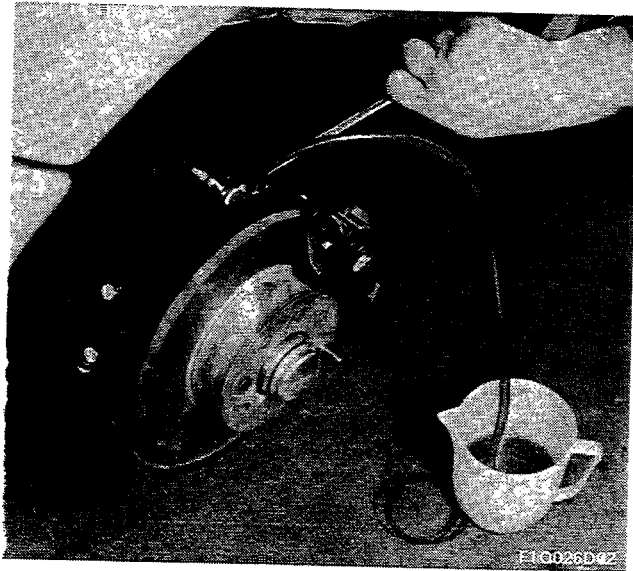

#### BLEEDING

It is not advisable to reuse the brake fluid collected. The level should be topped up using new brake fluid.



*In order to carry out the bleeding the suspension must be compressed in such a way that the load proportioning valve comes into operation.*

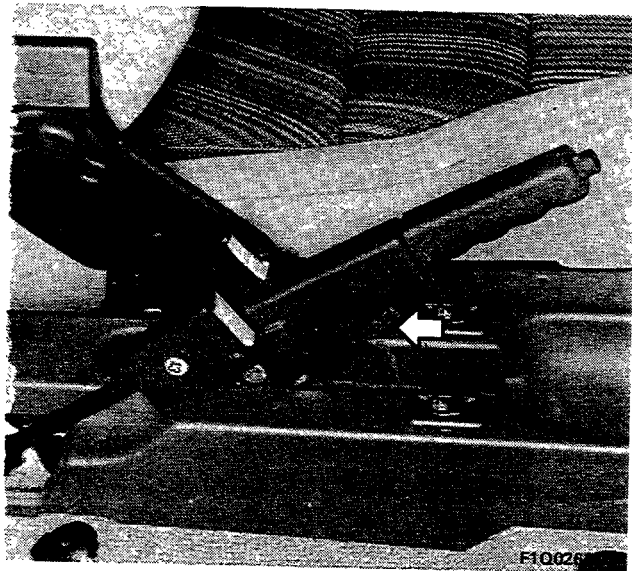

#### HANDBRAKE

##### Handbrake adjustment

**NOTE** *After carrying out the adjustment, the handbrake lever should not travel through more than 4 or 5 notches and the wheels should turn freely when it is released.*

DESCRIPTION	Thread size	Tightening torque
		daNm
Front brake caliper to steering knuckle fixing, bolt	M10 x 1,25	4,8
Front brake disc to hub fixing, bolt	M8 x 1,25	1,2
Front brake disc to hub fixing, bolt	M8 x 1,25	2,3
Load proportioning valve to bracket fixing, bolt	M8 x 1,25	2,5
Unions for tubes with split cone ends for fixing brake pipes to pump and load proportioning valve	M10 x1	1,8
Union for fixing brake pipes to load proportioning valve	M12 x1	1,8
Union for fixing flexible pipe to front brake cylinder	M10 x1	2,3
Union for fixing flexible brake pipe to rear brake cylinder	M10 x 1	1,2
Rear brake caliper to support bracket fixing, bolt	M10 x 1,25	3,6
Brake caliper mounting bracket to stub axle fixing, bolt	M8 x 1,25	2,5
Rear brake disc to hub fixing, bolt	M8 x 1,25	1,2
Rear brake disc to hub fixing, bolt	M8 x 1,25	2,3